

# THE SINGAPORE ENGINEER

August 2020 | MCI (P) 004/03/2020

## COVER STORY:

The first high-rise junior college  
in Singapore



## PLUS

**GREEN BUILDINGS:** More buildings aiming for best-in-class energy performance certification

**RAILWAY & ROAD ENGINEERING (ELECTRICAL & ELECTRONICS):** Railway systems 'cybersecured by design'

**DIGITALISATION:** The sprawling reach of complex threats

# Make your mark on a new frontier.



**Nachiappan Saravanan**  
BEng Electronics

## Make your move to SUSS.

The SUSS School of Science and Technology (SST) strives to prepare job-ready graduates for a successful career in the real world by providing a rigorous and profession-centric education that links working adults with experienced practitioners to create a productive workforce that contributes to society.

- Aerospace Systems
- Biomedical Engineering
- Biomedical Engineering with Paramedicine and Emergency Response
- Building and Project Management
- Digital Media
- Electronics
- Facilities and Events Management
- Human Factors in Safety
- Information and Communication Technology
- Information Technology and Business (ERP)
- Mathematics



For the greater good.

**SUSS**  
SINGAPORE UNIVERSITY  
OF SOCIAL SCIENCES



Apply now at  
[suss.edu.sg/apply](https://suss.edu.sg/apply)

6248 9777 [suss.edu.sg](https://suss.edu.sg)

[f](https://www.facebook.com/suss.sg) [suss.sg](https://www.facebook.com/suss.sg)

[@suss\\_sg](https://twitter.com/suss_sg)

[i](https://www.instagram.com/suss.sg) [suss.sg](https://www.instagram.com/suss.sg)

[in](https://www.linkedin.com/company/suss.sg) Singapore University of Social Sciences

Railway & Transport



Infrastructure



Marine & Offshore



Energy



Chemical & Process



Aerospace



Systems

Environmental & Water

# CHARTERED ENGINEER

(SINGAPORE)

Have your competency recognised!

For more information, visit our website at  
[www.charteredengineers.sg](http://www.charteredengineers.sg)

# CONTENTS

## FEATURES

### COVER STORY

- 14 The first high-rise junior college in Singapore**  
The project has overcome space constraints and boasts several achievements.

### GREEN BUILDINGS

- 21 More buildings aiming for best-in-class energy performance certification**  
More building owners are aware of the positive impact of green buildings and recognise them as key in efforts to fight climate change.

### RAILWAY & ROAD ENGINEERING

- 24 Railway systems 'cybersecured by design'**  
This can be delivered in compliance with international references and standards.
- 28 Decision support for traction power supply operation in real-time**  
Dependable traction power supply availability is a major prerequisite for metro operators to provide high-quality services to their passengers.

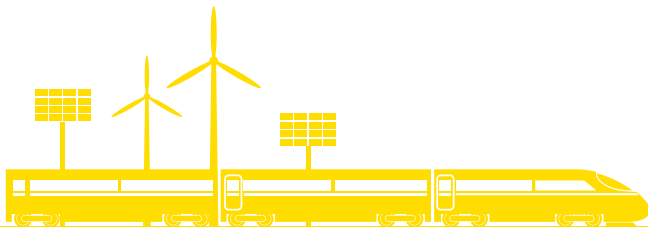
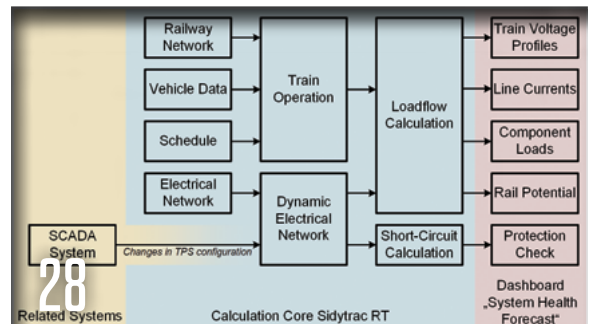

President  
**Dr Richard Kwok**  
Chief Editor  
**T Bhaskaran**  
t\_b\_n8@yahoo.com

Publications Manager  
**Desmond Teo**  
desmond@iesnet.org.sg  
Publications Executive  
**Queek Jiayu**  
jiayu@iesnet.org.sg

Editorial Panel  
**Dr Chandra Segaran**  
**Prof Er Meng Joo**  
**Dr Ang Keng Been**  
**Mr Gary Chiam**  
**Dr Victor Sim**  
**Mr Syafiq Shahul**  
**Dr Alexander Wiegand**  
Media Representative  
**Multimedia Communications**  
(2000) Pte Ltd  
sales@multimediacomms.sg

Design & layout by **2EZ Asia Pte Ltd**  
Cover designed by **Irin Kuah**  
Cover images by  
**CPG Consultants Pte Ltd**

Published by  
**The Institution of Engineers, Singapore**  
70 Bukit Tinggi Road, Singapore 289758  
Tel: 6469 5000 | Fax: 6467 1108

Printed in Singapore

## DIGITALISATION

- 32 Remote collaboration solves the test bench paradox**  
A solution is offered that addresses the complexity of test and analysis.
- 34 How digital transformation is shaping the oil & gas industry**  
Adoption of this initiative is vital for optimising asset performance.
- 36 The sprawling reach of complex threats**  
The second and final part of the edited contents of the 2019 Annual Security Roundup Report by Trend Micro Incorporated is presented.



## REGULAR SECTIONS

- 04 INDUSTRY NEWS
- 43 PRODUCTS & SOLUTIONS
- 47 IES UPDATE

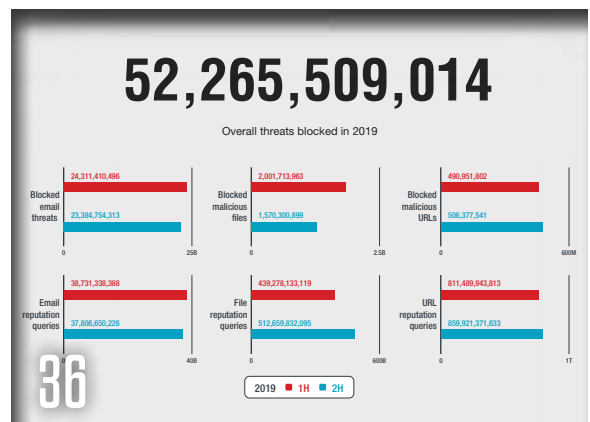

*The Singapore Engineer* is published monthly by The Institution of Engineers, Singapore (IES). The publication is distributed free-of-charge to IES members and affiliates. Views expressed in this publication do not necessarily reflect those of the Editor or IES. All rights reserved. No part of this magazine shall be reproduced, mechanically or electronically, without the prior consent of IES. Whilst every care is taken to ensure accuracy of the content at press time, IES will not be liable for any discrepancies. Unsolicited contributions are welcome but their inclusion in the magazine is at the discretion of the Editor.

# PRODUCING MEDICAL GRADE FACE SHIELDS

## FOR COVID-19 FRONTLINERS IN SINGAPORE

Siemens Advance Manufacturing Transformation Center (AMTC), a newly set up competence centre based in Singapore, led an ecosystem of Industry 4.0 partners to develop and manufacture a medical grade face shield frame using additive manufacturing. The face shield was designed by Tan Tock Seng Hospital (TTSH).

The collaboration saw Siemens AMTC as well as Agency for Science, Technology and Research (A\*STAR), HP's Smart Manufacturing Applications and Research Center (SMARC), and Mitsui Chemicals (Japan), coming together to design, optimise and manufacture the face shields in an accelerated product introduction cycle of under two months. TTSH provided feedback during this process to ensure that the face shields are comfortable to wear and can be easily cleaned.

AMTC provides guidance and support to ASEAN manufacturers on their journey towards advanced manufacturing.

Through Siemens' in-house additive manufacturing expertise and local network, the face shield frame design was optimised and printed using HP's Multi Jet Fusion (MJF) 3D technology with proprietary polyamide material, that is certified biocompatible by US Food and Drug Administration (FDA), and Mitsui Chemical's polyolefin coating that is approved for medical use.

After stringent selection and testing of various medical grade coatings, Mitsui Chemical's coating was selected as the most suitable one for the MJF-printed face shield frame. This specialised coating is used to make the frame of the face shield stronger, smoother and more flexible, as well

as more capable of withstanding repeated use of the chemicals commonly used for sterilisation. The process for applying the coating was developed by scientists from the Bioactive Polymer Team at A\*STAR's Institute of Materials Research and Engineering (IMRE).

"We are glad that Siemens and its partners have helped us to optimise our 3D printed face shield to have enhanced durability

and strength as we continue to fight the battle against COVID-19. We are all in this together and it is great to be part of a local collaboration in supporting the fight against the global pandemic", said Ms Lynette Ong, Director, Transformation, Tan Tock Seng Hospital.

Siemens NX CAD software was used to optimise nesting for production, resulting in an increase in production capacity from 200 units to 3000 units per month. Through the AMTC network, this is set to increase to 18,000 units per month as more 3D printers are added to the production line.

"This face shield project has proven the capabilities and benefits of additive manufacturing and Industry 4.0 technologies. It is exactly why Siemens set up the AMTC - we want to help companies to adopt advanced manufacturing so as to be agile and competitive in today's fast-changing economy", said Benjamin Moey, Head of Additive Manufacturing, Siemens, APAC.

"Our strong and diverse ecosystem of partners allow industries to reap the benefits of Industry 4.0 without the necessity of engineering from scratch, each time, thus saving time and money. This is especially crucial and valuable during challenging times, such as the current COVID-19 situation", he added.

In response to the ongoing global health crisis caused by the outbreak of the COVID-19 virus, Siemens has opened its global additive manufacturing network to enable the efficient execution of design and printing requests by doctors, hospitals and suppliers of medical equipment.

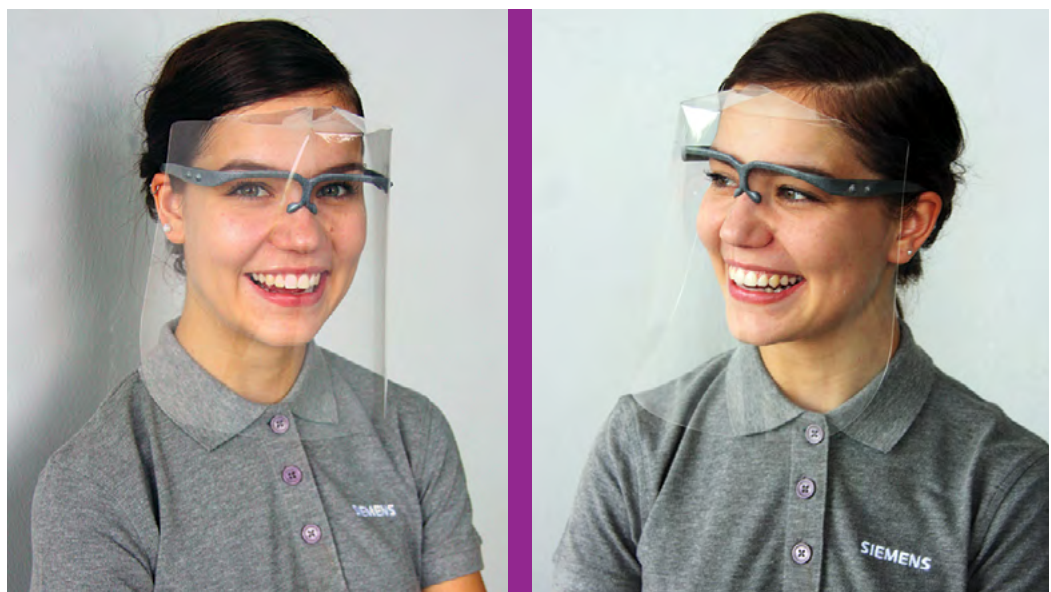

The grey spectacle frame for the medical-grade face shields has been optimised and is produced using additive manufacturing, by the Siemens Advanced Manufacturing Transformation Center (AMTC) together with Industry 4.0 partners.

## PARTNERING TO DESIGN SUSTAINABLE AND

# RESILIENT URBAN DEVELOPMENTS IN ASIA

Nippon Koei, an international engineering consultant, and Surbana Jurong, a global multidisciplinary urban and infrastructure design consultancy, signed a Memorandum of Understanding (MoU) recently, committing to deliver sustainable and resilient solutions to urban and infrastructure development projects worldwide. This is part of the firms' joint action on climate change mitigation and resiliency.

According to the Weather, Climate & Catastrophe Insight 2019 Annual Report by AON, the economic losses resulting from weather disasters have been estimated at USD 232 billion globally in 2019. There is a growing need to build urban resilience against natural disasters and adopt smart solutions for sustainability. Under the MoU, Nippon Koei and Surbana Jurong will harness their combined knowledge and experience in climate change adaptation, resilience enhancement and smart technologies, to deliver these solutions.

Each partner will bring complementary expertise to this collaboration. Nippon Koei has proven capabilities in disaster preparedness in Japan and government-funded projects in other countries, including Official Development Assistance for world-class engineering design projects. Surbana Jurong, on the other hand, has a track-record in delivering innovative and smart solutions for sustainability and resiliency in master planning, urban, residential and industrial development, coastal protection and reclamation, around the world.

Both consulting firms have been collaborating on sustainability and resiliency, since 2018. A notable project is the 9,460-hectare New Clark City in the Philippines. Slated for completion in 2065, it will be the country's first smart, green and disaster-resilient metropolis. Building on strong ties, Nippon Koei and Surbana Jurong will identify sustainable project opportunities globally, especially in Asia where public-private partnerships can encourage the adoption of smart technologies to scale up urban

initiatives and solutions. This approach will contribute towards the shared vision of building sustainable and liveable cities.

Mr Ryuichi Arimoto, Representative Director and President of Nippon Koei, said, "I am therefore very glad that Surbana Jurong and Nippon Koei, both of which are leading the state-of-art urban development projects, will build on the work of our existing interdisciplinary collaboration for the benefit of sustainable society. The strategic partnership will integrate and enhance the development of the relevant research, planning, designing and implementation fields. It will also help nurture more local talent in multiple disciplines in the pursuit of real-world challenges and practical application for sustainable urban development all over the world. A variety of 'smart solutions', in line with the needs and economic viability, can be provided, as part of our services, by utilising advanced analysis technologies. It can also facilitate designing and implementing solutions to cater for regions with different tastes and styles, which in turn leads to personalised and sustainable development".

Mr Wong Heang Fine, Group Chief Executive Officer of Surbana Jurong, said, "Surbana Jurong has forged strong ties with Nippon Koei through several landmark projects over the years, including the recent 'Study of Cooperation for Infrastructure Projects', that will facilitate closer cooperation between Singapore and Japanese companies on infrastructure projects across Asia. These successes reflect our complementary capabilities for the built environment. Surbana Jurong is pleased to renew our partnership with Nippon Koei, extending our expertise in smart solutions to jointly tackle new and complex urban challenges and advance sustainable development. We look forward to contribute towards a greener, more resource-efficient and liveable environment for future generations".



Mr Ryuichi Arimoto, Representative Director and President of Nippon Koei (left), and Mr Wong Heang Fine, Group Chief Executive Officer of Surbana Jurong, signed a Memorandum of Understanding, committing to deliver sustainable and resilient solutions to urban and infrastructure development projects worldwide.



Artist's impression of New Clark City in the Philippines. Nippon Koei and Surbana Jurong have been collaborating on the 9,460-hectare project.

# DRIVING AI-BASED INNOVATIONS IN COGNITIVE BUILT ENVIRONMENT TECHNOLOGIES

With the help of the Singapore Economic Development Board (EDB), Johnson Controls, a global leader in building technologies and solutions, will set up a SGD 50 million innovation lab to pioneer a new branch of digital technology that blends building, spatial and behavioural data with analytics and machine learning. Scheduled to open by the end of September this year, the lab is expected to have more than 100 employees within four years. The investment is part of Johnson Controls' commitment to spearhead the creation and adoption of disruptive solutions for the built environment industry as well as to accelerate digital transformation.

Alvin Ng, Vice President, Digital Solutions, Asia Pacific, Johnson Controls, said, "Urban living needs a reboot in the wake of a global pandemic. We see a renewed urgency to strengthen the resilience of our community and an opportunity to enhance sustainability. This innovation lab has a unique focus on the intersection of technology, people and space, creating new value for organisations and end users".

The lab will take on a multi-pronged strategy that covers research, collaboration, commercialisation and implementation. The resulting slew of customisable, autonomous or voice-activated solutions will meet the expectant growth for contactless applications, following societal adoption of safety and social-distancing measures as the post-pandemic norm. Property owners, facilities managers, business users and building occupants are among the target groups expected to benefit.

The strategy includes the following:

- Forming partnerships with key local research organisations to leverage Johnson Controls' deep domain expertise in building technologies (such as heating ventilation, air-conditioning, lighting and security) to accelerate innovation in software engineering and product development. Key areas include edge devices, Internet of Things (IoT) and Artificial Intelligence (AI).
- Working with property developers and building owners to create 'cognitive buildings' or thinking buildings that can understand, or even predict, occupants' preferred ambient settings and recognise space usage patterns. Such innovation will improve energy usage, increase the commercial attractiveness of the property, and enhance its environmental, social and governance (ESG) metrics. This is done through collaboratively developing solutions that apply advanced algorithms to a mash of data sets collected from Johnson Controls' open platform of building solutions, consumer wearables, networked devices, location data and Johnson Controls' Digital Twin.
- Building an ecosystem comprising lifestyle, fitness and smart furniture datapoints. The data can be used for



The lab will take on a multi-pronged strategy that covers research, collaboration, commercialisation and implementation.

designing business and personal spaces. For example, a workplace with flexible furniture can be configured into 'pods' for private videoconferencing or extended to become 'conversation lounges' for small group collaboration. Building occupants can also benefit from timed artificial lighting that mimics the changing natural light throughout the day.

- Engaging with professional bodies to deliver the new applications that impact the sustainability and resilience of local properties, as well as setting the standards for delivery of professional services in this field.

Tan Kong Hwee, Executive Vice President, EDB, said, "Johnson Controls' decision to set up its innovation lab in Singapore underscores Singapore's attractiveness as a location for companies to develop and commercialise new digital solutions for the global market. We welcome Johnson Controls' approach of partnering with the vibrant ecosystem in Singapore even as it plans to build a substantial development team in Singapore. We look forward to the impactful solutions that Johnson Controls will create, and the exciting job opportunities for Singaporeans in areas such as software engineering, data science and cybersecurity".

"We are excited to partner with EDB and plug into the vibrant ecosystem in Singapore. As a pure-play intelligent building solutions provider, our depth of assets, resources and domain knowledge gives us insights on the way forward for the built environment. This new innovation facility in Singapore will play a pre-eminent role in reshaping how we approach intelligent built environment technologies, and to attract like-minded talents who are eager to make a difference in Singapore and beyond", said Visal Leng, Vice President and President, Building Solutions, Asia Pacific, Johnson Controls.



## COLLABORATION TO DEVELOP

# END-TO-END DECARBONISATION PROCESS

Industry leaders, Keppel Data Centres, Chevron, Pan-United, and Surbana Jurong, with the support of the National Research Foundation, signed a Memorandum of Understanding (MoU) recently, committing to harness their combined resources and jointly develop the first end-to-end decarbonisation process in Singapore. This collaboration is aimed at accelerating the development of a highly integrated clean and energy-efficient Carbon Capture, Utilisation & Sequestration (CCUS) system that can lead to a low-carbon economy and potential commercial developments for Singapore.

Carbon emissions make up 97% of Singapore's total greenhouse gas emissions. Under the Paris Agreement, Singapore has pledged to, by 2030, reduce its emissions intensity by 36% from 2005 levels, and to stabilise its emissions

and peak around 2030. The Singapore Government has announced its long-term strategy to halve emissions from its 2030 peak and achieve net-zero emissions as soon as is viable. To this end, the partnership will develop CCUS technologies that are readily applicable to Singapore's key industries such as energy, chemicals and construction.

Under the MoU, Keppel Data Centres, Chevron, Pan-United, and Surbana Jurong will jointly explore, identify and develop mature carbon capture technologies, coupled with novel technologies that utilise cryogenics, membranes and hydrogen. The four companies will also leverage the combined resources, knowledge and capabilities with other research partners, Institutes of Higher Learning and international partners, to advance the development of the CCUS technologies.

*YOUR NEXT HIRE IS HERE...*

*PLACE YOUR  
JOB LISTINGS  
WITH US TODAY*



**EDM**



**Magazine**



**Website**



**Rates start from as low as \$350**

For more information, please e-mail  
[desmond@iesnet.org.sg](mailto:desmond@iesnet.org.sg) or [fenda.ngo@iesnet.org.sg](mailto:fenda.ngo@iesnet.org.sg)

# REDUCING THE CARBON FOOTPRINT OF ARTIFICIAL INTELLIGENCE

In June 2019, researchers at the University of Massachusetts at Amherst released a report estimating that the amount of power required for training and searching a neural network architecture involves the emission of roughly 626,000 pounds (284,000 kilograms) of carbon dioxide, equivalent to nearly five times the lifetime emissions of the average American car, including its manufacturing.

This issue is exacerbated in the model deployment phase, where deep neural networks need to be deployed on diverse hardware platforms, each with different properties and computational resources.

MIT researchers have developed a new automated AI system for training and running certain neural networks. Results indicate that, by improving the computational efficiency of the system in some key ways, the system can cut down the carbon emissions involved.

The researchers' system, which they call a once-for-all network, trains one large neural network comprising many pre-trained sub-networks of different sizes that can be tailored to diverse hardware platforms without retraining.

This dramatically reduces the energy usually required to train each specialised neural network for new platforms, which can include billions of Internet of Things (IoT) devices.

Using the system to train a computer-vision model, they estimated that the process required roughly 1/1,300 the carbon emissions compared to today's state-of-the-art neural architecture search approaches, while reducing the inference time by 1.5 to 2.6 times.

"The aim is smaller, greener neural networks," says Song Han, an assistant professor in the Department of Electrical Engineering and Computer Science.

"Searching efficient neural network architectures has until now had a huge carbon footprint. But we reduced that footprint by orders of magnitude with these new methods."

The work was carried out on Satori, an efficient computing cluster donated to MIT by IBM that is capable of performing 2 quadrillion calculations per second. Prof Han's team members comprise four undergraduate and graduate students from EECS, the MIT-IBM Watson AI Lab, and Shanghai Jiao Tong University.

The researchers built the system on a recent AI advance called AutoML (for automatic machine learning), which eliminates manual network design. Neural networks automatically search massive design spaces for network architectures tailored, for instance, to specific hardware platforms.

However, each model has to be selected then trained from scratch for its platform architecture.

The researchers invented an AutoML system that trains only a single, large "once-for-all" (OFA) network that serves as a "mother" network, nesting an extremely high number of subnetworks that are sparsely activated from the mother network.

OFA shares all its learned weights with all subnetworks – meaning they come essentially pre-trained. Thus, each subnetwork can operate independently at inference time without retraining.

Given a specific platform, the system uses the OFA as the search space to find the best subnetwork based on the accuracy and latency trade-offs that correlate to the platform's power and speed limits.

For an IoT device, for instance, the system will find a smaller subnetwork. For smartphones, it will select larger subnetworks, but with different structures depending on individual battery lifetimes and computation resources.

OFA decouples model training and architecture search, and spreads the one-time training cost across many inference hardware platforms and resource constraints.

This relies on a "progressive shrinking" algorithm that efficiently trains the OFA network to support all of the subnetworks simultaneously. It starts with training the full network with the maximum size, then progressively shrinks the sizes of the network to include smaller subnetworks.

Smaller subnetworks are trained with the help of large subnetworks to grow together, thus supporting all network sizes and allowing fast specialization based on the platform's power and speed limits.

Commenting on the research, Dr John Cohn, an IBM fellow and member of the MIT-IBM Watson AI Lab, said: "If rapid progress in AI is to continue, we need to reduce its environmental impact ... The upside of developing methods to make AI models smaller and more efficient is that the models may also perform better."

## MIT-led AI institute

The US National Science Foundation (NSF) recently announced an investment of more than USD 100 million to establish five AI institutes, each receiving roughly USD 20 million over five years. One of these, the NSF AI Institute for Artificial Intelligence and Fundamental Interactions, will be led by MIT's Laboratory for Nuclear Science.

## CAPITALAND SECURES SGD 400M IN GREEN LOANS TO CATALYSE GREENING OF GLOBAL PORTFOLIO BY 2030

CapitaLand has secured a total of SGD 400 million in two bilateral green loans to catalyse greening of the group's global portfolio by 2030. This consists of a SGD 150 million four-year green loan from DBS, as well as a SGD 250 million three-year multi-currency green loan from HSBC Singapore.

Proceeds from these loans will be used towards the financing or refinancing of the development, investment and acquisition of certified green buildings.

The green buildings must achieve or is expected to achieve minimally a Green Mark Gold<sup>PLUS</sup> certification by BCA or a Leadership in Energy and Environmental Design Gold rating by the United States Green Building Council.

The first such building to come under this initiative is the group's LogisTech building, which was awarded BCA's Green Mark Platinum 'Super Low Energy (SLE)' certification, making it the first logistics building here to attain this achievement with at least 40 per cent energy saving based on the prevailing building code.

The four-storey building underwent a major upgrade to achieve its energy efficiency standard. LogisTech's installation of solar panels at its rooftop is estimated to generate over 2,000 megawatt hour (MWh) of energy per year, which is used to power the building.

In total, it is expected to save over 3,900 MWh each year, equivalent to the annual electricity consumption

of about 918 four-room HDB flats. Other newly implemented initiatives include a highly efficient water-cooled chiller plant and high-efficiency air handling units.

LogisTech has also implemented a smart facilities management system which automatically detects, diagnoses and informs the building's operations team for quicker rectification.

Aside from the funding arrangement, CapitaLand also said that its corporate offices across three locations in Singapore will be fully powered by renewable energy by end-2020. This will avoid over 700 tonnes of carbon emissions each year, equivalent to carbon emissions from the annual electricity consumption of 400 four-room HDB flats, and furthers the Group's objective to achieve at least 20 per cent energy consumption from renewable energy by 2025.

This will be accomplished through the purchase Renewable Energy Certificates (REC) from the clean energy generated from over 21,000 solar panels installed atop CapitaLand's six industrial properties here, held under Ascendas Reit. The RECs will be used to reduce carbon emissions at CapitaLand's corporate offices within Capital Tower, Galaxis and eCapitaHub.

After 2022, a projected total of 2,400 tonnes of carbon emissions are expected to be avoided each year, equivalent to carbon emissions from the annual electricity consumption of about 1,300 HDB flats.



The LogisTech building, located along Changi North Street 2, is the first logistics building to attain the BCA Green Mark Platinum SLE certification. Photo: CapitaLand Group

# EMA AND KEPPEL O&M COME TOGETHER TO SPARK INNOVATIVE ENERGY SOLUTIONS IN MARINE SECTOR

To facilitate innovation of marine sector energy solutions for greater environmental sustainability, the Energy Market Authority (EMA) and Keppel Offshore & Marine (Keppel O&M) have joined forces and signed an MoU to develop solutions in the areas of distributed energy resources, digitalisation and emerging low carbon alternatives.

As part of this MoU, EMA and Keppel O&M launched a grant call for solutions relating to energy storage systems and smart power grids for the offshore and marine environment, which closed on 24 June 2020. It is believed that the insights from the grant call could be translated to potential solutions to enhance the grid.

Shortlisted participants would have the opportunity to testbed their solutions through Keppel O&M's Floating Living Lab (FLL), the first-of-its-kind offshore floating testbed in Singapore.

Expected to be operational by end 2021, Keppel O&M's FLL will provide a platform for the industry and the research community to testbed and commercialise promising power and technology solutions for the marine sector.

The FLL will have Liquefied Natural Gas (LNG) bunkering facilities for harbour crafts and small vessels. It will also house an embedded power generation system to power Keppel O&M's operations, with excess electricity to be exported to the national grid.



Digital rendering of Keppel O&M's FLL. Image: EMA

Mr Chris Ong, CEO of Keppel O&M, said, "We are pleased to be able to partner EMA on developing innovative solutions for the energy and marine space. Our use of digitalisation and data analytics will reduce energy waste and increase the use of cleaner energy."

"(The) Floating Living Lab ... enables Keppel O&M to provide power for our own operations, support customers in delivering cleaner power, grow our LNG bunkering services and improve the efficiency of the current supply chain, while extending our gas offerings in the floating power segment. Keppel's drive to provide clean floating energy solutions will complement EMA's work in ensuring energy sustainability."

## SURVEY WORK BEGINS FOR AUSTRALIA-ASEAN UNDERSEA POWER LINK

Perth-based Guardian Geomatics has been awarded the cable route survey contract for the Sun Cable project, a multi-billion dollar project described as exporting "sunshine" to Asia.

The ambitious plan envisions a solar and battery storage farm, laid out across thousands of hectares in Australia's Northern Territory. The dispatchable renewable electricity will be supplied to Darwin, Singapore and Indonesia.

Singapore and Indonesia will be supplied via a 3,800km high voltage direct current submarine cable from Darwin. This Sun Cable project has been

touted as a "game-changer" for an economy reliant on coal and gas export revenues.

Guardian Geomatics Commercial Director Steve Duffield said, "Guardian Geomatics is always on the lookout for opportunities to improve our footprint and sustainability – this project is a step in the right direction and something we are very proud of."

Project preparations commenced in May, with initial plans to utilise sister company Guardian Offshore's vessel "Offshore Solution" to deliver the work, starting later in 2020. For more information on this multi-billion dollar renewable energy project, visit Sun Cable at <http://www.suncable.sg/>.

## NUS-ECOLINE SOLAR TEAM INVENT HYBRID AIR-CON THAT REDUCES ELECTRICITY CONSUMPTION

A new cooling technology, developed by NUS and Singapore-based company Ecoline Solar, is being installed in commercial buildings across the country.

The hybrid solar-thermal air-conditioner uses the heat from the sun and ambient surroundings to ease the electrical load of energy-guzzling compressors by up to 55 per cent.

NUS revealed that companies such as NCS Singtel and Highway International have adopted the technology. It has also been installed in some vertical farms and several condominiums and hotels.

“Today’s conventional air conditioners require high electrical energy and also produce a high volume of heat which is released into the environment, causing the creation of undesirable heat zones,” explained the team leader, Associate Professor Ernest Chua Kian Jon from the Department of Mechanical Engineering, NUS.

“The NUS and Ecoline innovative hybrid system leverages solar thermal technology to markedly reduce energy consumption and cut the volume of heat dissipated to the environment through our specially designed condensing unit,” he said.

The jointly-developed solution utilises a solar thermal collector, comprising vacuum tubes filled with a novel medium specially designed and engineered by the NUS team to absorb more solar energy and ambient heat.

The harnessed energy is then recycled to assist in the superheating of the refrigerant in the system, converting it from a low pressure, low temperature gas into a high pressure, high temperature gas.

This reduces the system’s reliance on the compressor that pumps the refrigerant through the system and, in turn, reduces the system’s overall electricity consumption and greenhouse gas emission.

The team believes that the solar thermal air conditioning technology is poised to help Singapore and the world improve building energy

efficiency as it is potentially an effective way to reduce operating cost and the carbon footprint, thereby helping to reduce global warming.

Actual usage data has shown that the hybrid system has consistently resulted in the reduction of utility bills by 30 to 55 per cent, depending on usage patterns.

Director of Ecoline Solar Colin Chia noted that the efficiency of the hybrid air-con system rises with a warmer surrounding environment.

“This is a game changer in the air conditioning industry. For consumers, this translates to greater savings in electricity consumption even when compared to the best conventional and inverter air conditioning systems in the market,” he said.

The hybrid solar thermal air-conditioner is now available to consumers here. While it costs about 20 per cent more than an inverter air-conditioner, this cost difference is easily offset by the electrical cost savings in under two years. In the long run, this would be a more cost-effective cooling option.

The project was conferred the Prestigious Engineering Achievement Award by IES and the ASEAN Outstanding Engineering Achievement Award by AFEO in 2019.

The two collaborators are now working to incorporate NUS’ patented membrane dehumidification technology to the thermal-based air conditioner to yield even higher energy savings.



(From left) Assoc Prof Ernest Chua, Mr Colin Chia (Ecoline Solar), and Mr Liam Kok Aeng (Ecoline Solar) demonstrate their hybrid solar technology. Photo: NUS

# ALL-PEROVSKITE ARRANGEMENTS

## BEAT SILICON FOR SOLAR PV CELLS

Cornell University engineers have found that photovoltaic (PV) wafers in solar panels with all-perovskite structures outperform those made from state-of-the-art crystalline silicon, as well as perovskite-silicon tandem (stacked pancake-style cells that absorb light better) cells.

In addition to offering a faster return on the initial energy investment than silicon-based solar panels, all-perovskite solar cells mitigate climate change because they consume less energy in the manufacturing process, according to research published on 31 July 2020 in the journal *Science Advances*.

“Layered tandem cells for solar panels offer more efficiency, so this is a promising route to widespread deployment of photovoltaics,” said Professor You Fengqi, the leader of the study.

The energy systems engineering professor further noted that perovskites enabled affordable and efficient solar panel fabrication.

The paper, titled “Life Cycle Energy Use and Environmental Implications of High-Performance Perovskite Tandem Solar Cells”, compared energy and life-cycle environmental impacts of modern tandem solar cells made of silicon and perovskites.

Producing perovskite-only tandem solar cells leaves a smaller carbon footprint than silicon or perovskite-silicon tandem solar cells. Prof You described making silicon-only cells for solar panels as an energy-intensive process, requiring extreme pressure and heat, and leaving a large carbon footprint.

Comparatively, perovskite needs less processing, and much less of the heat or pressure, during the fabrication of solar panels.

Furthermore, silicon PVs require an expensive initial energy outlay, taking about 18 months to get a return on that investment. A solar cell wafer with an all-perovskite tandem configuration, according to the researchers, offers an energy payback on the investment in just four months.

Also, the perovskite tandem cell, throughout its lifespan, had an associated emission of about 10.69 grams of carbon dioxide equivalent per kilowatt-hour of electricity it generated, which is about 40 per cent of the emissions for silicon solar panels.

Another advantage of the perovskite tandem cells is that they are flexible enough to be installed on a variety of surfaces, such as on cars or bicycles.

As production increases and benefits from economies of scale, its price is likely going to be cheaper than silicon, noted Prof You. This is in spite of current literature suggesting that the lifespan of first-gen perovskite PVs being approximately half of that of equivalent benchmark silicon PVs.

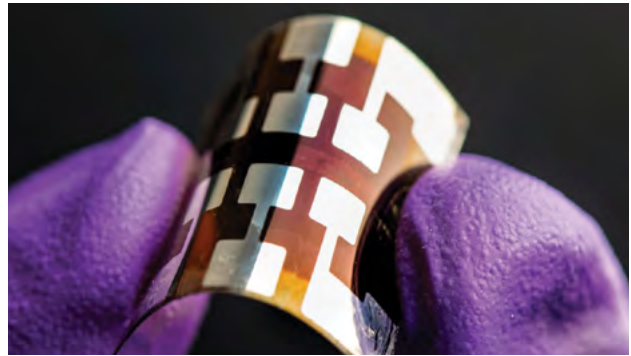

Example of a solar PV cell made with perovskite. Photo: National Renewable Energy Laboratory, US Department of Energy

## Funding for perovskite solar technologies

The US Department of Energy (DOE) recently announced USD 20 million in funding to advance perovskite solar photovoltaic technologies.

Some of the goals are to improve understanding of perovskite stability; establish methods to produce high-efficiency, stable perovskite devices using industry-relevant fabrication techniques; and develop test protocols that enable high confidence in long-duration field performance of perovskite-based photovoltaic technologies.

The US DOE will fund projects in three topic areas - Device R&D (Efficiency and Stability), Manufacturing R&D, and Validation and Bankability.

### Device R&D (Efficiency and Stability)

This topic area will focus on research projects to advance perovskite efficiency and stability at the cell or mini-module scale beyond the current state-of-the-art technology.

### Manufacturing R&D

This topic area will fund research projects to address challenges with manufacturing perovskite modules at relevant scale and throughput.

### Validation and Bankability

This topic area seeks to establish a neutral, independent validation centre that can be used to verify perovskite device performance and address acceptance and bankability challenges.

# RAILWAY SYSTEMS HANDBOOK

**ON SALE NOW**

**S\$35 / copy**

(self collect; before GST)



Edited by:

Pang Hock Lye, John

Cheong Mun Kit, Eric

Published by:



THE INSTITUTION OF ENGINEERS, SINGAPORE

Supported by:

SINGAPORE  
**RAIL ACADEMY**

Scan here  
to order



## THE FIRST HIGH-RISE

# JUNIOR COLLEGE IN SINGAPORE

In early January 2020, Eunoia Junior College moved to its new campus at 2 Sin Ming Place. The project has overcome space constraints and boasts several achievements including the adoption of green building features.



*Eunoia Junior College is Singapore's first high-rise junior college.*

Eunoia Junior College (EJC) is an architectural essay on integration and intensification. With a site area of only 4 hectares, which is about a third smaller than the conventional site area for junior colleges, the design challenge was to create an integrated learning environment that fosters interaction whilst meeting the diverse learning needs of the students.

Overlooking Bishan-Ang Mo Kio Park and located within close proximity to both Bishan and Ang Mo Kio estates, the 51,000 m<sup>2</sup> EJC takes on the enhanced role of an educational institute that plugs itself into the community.

### ELEVATED LEARNING

It was decided that in order to create the necessary spaces for the junior college on the comparatively smaller 4-hectare plot, the campus would have to be built vertically. A high-rise learning environment comprising a support system of multiple learning platforms for interaction and exchange was envisioned.

There are two learning towers, one 10-storeys and the other 12-storeys high. On this 'elevated learning' site, platforms have been segmented thematically for a more conducive and accessible academic environment. Three main learning platforms were conceived:

- The Forum on Levels 1 & 2 - an area for community and social enrichment.
- The Arena on Level 5 - an area for physical and sporting enrichment.
- The Curia on Levels 9 & 10 - an area for knowledge enrichment.

Leveraging on the 'elevated learning' concept, a 5-storey-high running track and field, also a first-of-its-kind, has been built, that connects to the learning towers via a link bridge at the same level. Building the running track and field above Kallang River successfully addressed site constraints.

Under the running track and field, the campus arcade on Levels 1 & 2 accommodates the canteen, parade square,



dance studios, multi-purpose hall, a range of activity rooms, a 900-seat auditorium, a lecture theatre and an indoor sports hall opening into it. Travelling north-south across the campus, this circulation spine forms an interaction area which allows students to carry out a range of activities from frisbee games to group discussions, throughout the day, facilitating bonding and encouraging active student life.

On Levels 9 & 10, breakout spaces for interaction and collaboration are designed beside the resource library and the staff room, for students and teaching staff to meet with ease.

On other levels in the vertical learning zone, varying scales of informal learning spaces are designed as extensions of the tutorial and seminar rooms. Some of these provide small group and private study spaces while others take the form of generous breakout spaces which can promote team interaction and collaboration.

### INTEGRATING WITH THE PARK

The design of EJC seeks a dialogue with the beautiful Bishan-Ang Mo Kio Park adjacent to it. The park is invited into the EJC campus - into central voids of the vertical teaching block and onto the learning spaces and platforms opening towards it. The park flows into the canteen and parade square, combining with them and emerging as one space. Conversely, the park can be seen as an extension of the learning environment in the junior college, with its programmes spilling out into the park. This is made possible with the new link bridge connection to the park, over Kallang River.

Capitalising on the proximity with the park, the double volume resource library is strategically positioned on Levels 9 and 10, highlighting a sweeping connection with the external landscape, while providing a conducive space to support independent research and learning.

### ENGAGING THE COMMUNITY

The project sees, for the first time, the coexistence and integration of a junior college and a community club, under one roof. The Bishan North Community Club will provide students access to its facilities as well as a platform for them to go beyond the classroom and lead community projects. The integration of the community club will complement the college's service to community programmes and present an opportunity to foster greater connection and engagement with the residents of Bishan and Ang Mo Kio.

With the community club's physical connection to Bishan-Ang Mo Kio Park via a promenade and a link bridge, campus facilities such as the running track and field as well as the indoor sports hall are designed to be opened to the community at designated times.

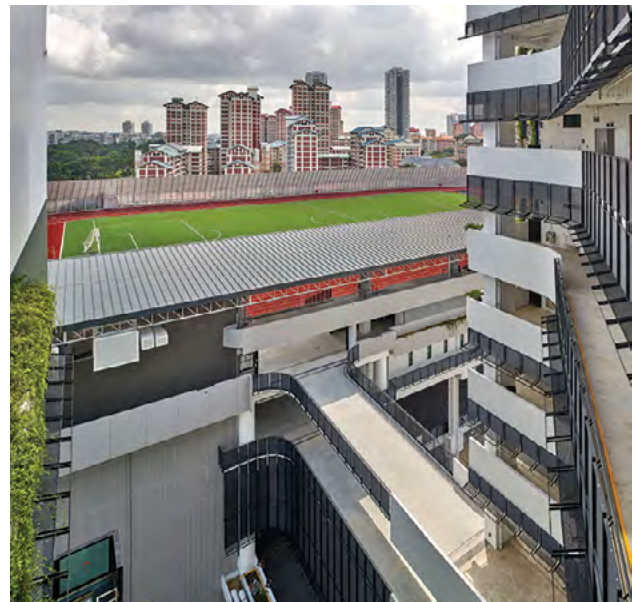

*The elevated running track and field located on top of the student activities block is a first-of-its-kind.*



*Large interaction areas facilitate student activities and bonding.*

# GREEN FEATURES

## FACADE

- Patterned concrete with window openings
- CLT wall with aluminium cladding
- Windows with adjustable louvres
- Curtain wall system with tinted Low-E glass

**High Performance Facade**

## LANDSCAPE

1. **Roof Garden** on the roof to reduce urban heat island

## LIFTS AND ESCALATORS

**VVVF Drive & sleep mode lift**



## AC SYSTEM

Centralized chilled water system with variable flow control.

## WATER MANAGEMENT

1. **Rain Water Detention system** to reduce the storm water run off
2. **Water Efficient Fittings**



The green features of the project enabled it to win a Green Mark Platinum Award, under the New Non-Residential Building category, at BCA AWARDS 2018.

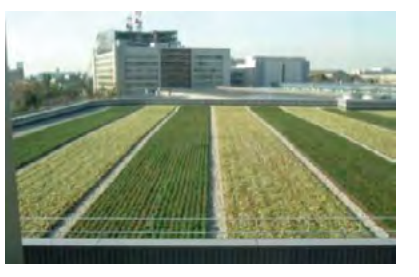

## MATERIAL

- 1. SGBC/SGLS Certified Materials.



## LIGHTING

- 1. LED Lighting
- 2. T5 Lamp
- 3. Motion Sensor



## IAQ (Indoor Air Quality)

- 1. Low VOC Material
- 2. CO and CO2 sensor



## DESIGN APPROACHES FOR A GREEN DEVELOPMENT

During the initial stages of the project, various passive simulation studies were carried out to specifically assess parts of the design process that could be made sustainable. Specifically, the passive design approach sought to maximise natural ventilation whilst ensuring thermal comfort.

The passive design analysis focused on the following four areas:

- Solar radiation
- Shading
- Daylighting
- Natural ventilation (sun and wind factors)

This research-based design approach allowed the design team to identify key concerns for improving both architectural and MEP designs, at an early stage. Based on various simulation analyses, refinements could be made by the design team in order to meet design goals relating to project sustainability and energy efficiency.

### Solar radiation and shading analysis

Solar simulation was carried out to find the optimal way to reduce heat gain and improve indoor comfort levels. Simulation tests were done on nine designs of shading devices with different solar shading parameters, in order to assess various ways of minimising heat gain and the mean radiant temperature.

### Daylight analysis

A daylighting design strategy was part of the green design approach. The objective of daylighting design is to reduce dependence on artificial lighting. A well-designed, daylighting plan is more than just putting together windows and skylights in a building. An extensive daylight analysis was conducted to achieve the right balance between allowing substantial natural daylight to fill the spaces and minimising solar heat gain. Through daylighting simulation, designers were able to analyse daylight distribution and find ways to maximise illumination by natural light throughout the campus.

### Sun hour analysis

The elevated track and field provided a good opportunity for using the extra space for greening. The design team decided to introduce greenery under the elevated soccer field. In order to enable the architects and landscape designers to identify and choose suitable types of plants that are able to thrive in this environment, sun hour analysis was performed, that helped to determine the optimal number of hours of direct sunlight that the vegetation can receive and under which it can still flourish.

### Wind analysis

To ensure that students have a conducive study environment, it was essential to determine the thermal comfort level. Wind simulation was conducted using CFD software, in accordance with the Building and Construction Authority's (BCA) simulation guidelines, to evaluate and enhance the thermal comfort level of classrooms. The wind analysis process began with a macro approach

examining the site, to check the effectiveness of natural ventilation on the site surroundings. Tweaks were then made in the facade design to maximise cross ventilation in the classrooms. If, after optimisation of the building and window design, the simulation results still identified any areas that were under-ventilated, ceiling fans were incorporated, to achieve the indoor thermal comfort. As the classroom spaces are now sufficiently ventilated, both naturally and with the assistance of mechanical ventilation fans, the dependence on air-conditioning is reduced, resulting in a lower carbon footprint for the project.

### The use of Mass Engineered Timber

The facade and floor panels of the college are designed with cross-laminated timber (CLT) and glue-laminated timber (GLULAM), respectively.

CLT is used for a facade area of approximately 2600 m<sup>2</sup>, representing about 33% of the combined facade area for the north and south elevation. The adoption of CLT and GLULAM, which were made from spruce obtained from sustainable forests overseas, helped reduce the time taken for the installation of the floor and facade panels, during construction.

The use of wood for the interiors of the learning environment also provides materiality to the space, creating a natural warmth and rekindling a connection with nature.



*Interwoven with greenery, the multiple floors are easily accessible.*

Furthermore, the use of Mass Engineered Timber contributes to sustainability, as timber is a renewable resource and has a negative carbon footprint.

### Energy-efficient ACMV system

EJC is one of the most energy efficient junior colleges in Singapore, with energy efficiency achieved through carefully designed mechanical and electrical systems for air-conditioning and mechanical ventilation. In Singapore's tropical climate, air-conditioning is responsible for a large part of the energy consumption. To support and sustain the cooling of a large campus, instead of using Direct Expansion (DX) air-conditioning systems, the more energy saving centralised chilled water cooling method was adopted. A centralised chilled water plant with a cooling demand of about 300 RT can accommodate the cooling requirements of several areas such as the 900-seat auditorium, theatres and administrative spaces.

The chilled water system operates with an electricity consumption of less than 0.55 kW/RT, which is about 25% more efficient than the conventional VRV systems used in most schools, thereby contributing to significant savings in terms of operation and utility costs. Prior to site installation, an integrated design approach using REVIT 3D modelling was adopted throughout the project development stage to ensure that the equipment was well-coordinated and functioning.

### Water efficiency

The water requirements for the development are met with potable water supply from PUB, Singapore's national water agency; NEWater (highly treated, reclaimed wastewater); and rainwater harvested in detention tanks which collect water from roof gutters. About 30 m<sup>3</sup> of the rainwater that is harvested by the detention tanks are transferred to the irrigation tank, as top up for landscape irrigation (which requires about 79 m<sup>3</sup>/day).

The use of the rainwater collected for landscape irrigation, and NEWater as make-up water for cooling towers, helps reduce the usage and contamination of potable water. The installation of WELS-certified water fittings further improves water efficiency.

## OTHER CONSIDERATIONS

### Elevators and staircases

As EJC is the first high-rise junior college in Singapore, the vertical transportation system had to be



*Using Mass Engineered Timber improved buildability and contributes to environmental sustainability. The use of wood for the interiors rekindles a connection with nature.*

designed to be of the right size, in order to ensure there is no overcrowding, whilst at the same time, fulfilling all safety requirements. Elevator simulation studies were carried out to determine the optimum number of elevators and also to obtain suggestions for improvement.

As with elevators, the right number of staircases also had to be determined. Through pedestrian simulation studies, using VISSIM software, the number of staircases needed during peak events, such as the Sports Day, was determined. As a result of the simulation, it was estimated that all students could reach the ground level via the staircases or elevators, within 25 minutes (which includes the walking time within the sports ground).

In the event of an emergency evacuation, as no elevators can be under operation, the maximum travel time from each level of the academic block to Level 1 was also assessed. In performing these assessments, a normal walking speed was used and the essential number of staircases was derived, based on the premise that all occupants from each level of the campus should be able to reach Level 1 via the staircases within 10 minutes.

### Fire protection

With an elevated track and field, this project called for added attention to meet fire safety requirements. Performance-based fire simulation of the area under the track and field was conducted to ensure that all fire code requirements are met.

In addition, a code-compliant Engineered Smoke Control System (ESCS) was designed for the 900-seat auditorium. As per the recommendation of Fire Code 2013, a design fire size of 2.5 MW was used for the auditorium.



A code-compliant Engineered Smoke Control System (ESCS) was designed for the 900-seat auditorium.

All images by CPG Consultants Pte Ltd

## PROJECT DATA

**Client/Developer**  
Ministry of Education

**Architect**  
CPG Consultants Pte Ltd

**M&E Engineer**  
CPG Consultants Pte Ltd

**Structural Engineer**  
CPG Consultants Pte Ltd

**Quantity Surveyor**  
CPG Consultants Pte Ltd

**Main Contractor**  
Kimly - Lian Ho Lee Joint Venture

**ESD Consultant**  
CPG Consultants Pte Ltd



Through pedestrian simulation studies, the right number of staircases was determined.

# MORE BUILDINGS AIMING FOR BEST-IN-CLASS ENERGY PERFORMANCE CERTIFICATION

More building owners are aware of the positive impact of green buildings and recognise them as key in efforts to fight climate change.

A total of 376 projects, including 16 from overseas, have been awarded the Building and Construction Authority (BCA) Green Mark Award this year. Twenty-two of them have obtained the pinnacle level Green Mark Super Low Energy Building (GM SLEB) Award, among whom are three Positive Energy and three Zero Energy buildings. To-date, a total of 39 projects, involving 50 industry stakeholders, have received the GM SLEB Award.

The upward trend, with building owners going for higher tier Green Mark Certifications (Green Mark Platinum and above), is indicative of the industry's awareness of the positive impact of green buildings and recognising them as key in our efforts to fight climate change. For example, the number of Non-Residential Building projects obtaining Green Mark Platinum and above has doubled to 149 over the past five years.

Major Singapore developers, such as CapitaLand, City Developments Limited (CDL) and Keppel Land have also been setting targets for reducing energy use and the carbon footprint in their building portfolios.

## BENEFITS IN MAKING INVESTMENTS FOR HIGHER ENERGY EFFICIENCY

An independent review of BCA's Green Mark scheme carried out in 2019 assessed the total lifecycle cost across both residential and non-residential buildings. The study affirms that Green Mark certified buildings would be able to reap net positive savings throughout their lifecycle, with energy savings outweighing the upfront investment.

## GREEN MARK CHAMPION AWARD

CapitaLand Group has clinched the Green Mark Platinum Champion Award this year, setting a high standard among the Green Mark Champion winners. CapitaLand is the third organisation to achieve this feat. The award recognises developers who demonstrate strong commitment towards corporate social responsibility and have achieved a substantial number of Green Mark Gold buildings or higher.

The real estate group has also achieved BCA's Green Mark Platinum SLEB certification for LogisTech, the first logistics building in Singapore to achieve this recognition. The four-storey building underwent a major upgrade to achieve higher energy efficiency standards.

CapitaLand Group has separately accomplished the installation of 21,000 solar panels atop LogisTech and five other CapitaLand industrial properties in Singapore.

It will enable CapitaLand's corporate offices in three locations in Singapore to be 100% powered by renewable energy by end-2020, through Renewable Energy Certificates (REC) from the clean energy generated. As such, CapitaLand will reduce over 700 tonnes of greenhouse gas emissions each year.

Aside from that, CapitaLand has installed a climate-friendly refrigerant chilled-water system at the newly developed Funan. This has prevented about 5 kilo-tonnes of greenhouse gas being emitted - equivalent to the emissions of about 1,500 cars. Over time, the energy cost savings from the improved energy efficiency would more than cover the initial cost of the equipment.

CapitaLand has also secured SGD 1.2 billion in green loans which will be used to accelerate its efforts towards greening its global portfolio by 2030.

Other winners of the Green Mark Champion Award are National Environment Agency (NEA), Singapore Police Force (SPF), UOL Group Limited, and GuocoLand. The winners have shown a strong commitment to shaping a sustainable built environment.

## BCA-HPB GREEN MARK FOR HEALTHIER WORKPLACES

Strengthening the good linkage between energy efficiency, resource efficiency and healthier interior spaces, BCA collaborated with Health Promotion Board (HPB) to develop the BCA-HPB Green Mark for Healthier Workplaces (GM HW) scheme in 2018.

Placing occupants' health, well-being and comfort at the forefront of office design and daily operations, GM HW seeks to create a supportive environment through the establishment of workplace health structures, policies and programmes.

In achieving the GM HW certification this year, Space Lab One Pte Ltd stood out with its project, csuites. The project is the first co-tenanted workplace in Singapore to be awarded the Green Mark for Healthier Workplaces Platinum certification. csuites carries both green and health promoting features, including a biophilic design to promote mental well-being, active workspace elements, energy-efficient lighting along with the comprehensive Green Lease for all tenants.

As part of csuites' workplace health promotion efforts, a range of structured programmes, covering mental well-being, healthy eating, physical activity and chronic disease management, is also made available to employees.

## BRINGING BCA GREEN MARK OVERSEAS

The BCA Green Mark has received strong acceptance internationally, since it was launched 15 years ago. To-date, some 305 projects across 16 countries have attained the Green Mark certification. Singapore consultants such as GreenA Consultants (an environmental sustainability consultancy firm) are exporting their expertise overseas to meet the strong demand for green buildings in other cities.

GreenA is currently involved in 4 SLEB projects and has participated in more than 15 overseas Green Mark projects. Some of the firm’s notable international projects include New Bugesera International Airport (Rwanda) and Galleries Lafayette Shanghai (China).

## UPDATES ON THE SINGAPORE GREEN BUILDING MASTERPLAN

Since the beginning of 2020, BCA and the Singapore Green Building Council (SGBC) together with industry stakeholders have formed the Singapore Green Building Masterplan (SGBMP) Working Committee to collectively set a shared vision and aspirations for the next phase in Singapore’s green building journey.

A vital part of the work has been to engage a wider group of stakeholders, beyond the traditional Built Environment stakeholders, in the co-creation process. This includes tenants and youth who represent the ultimate beneficiaries of a greener Built Environment as envisaged in the SGBMP.

Members of the public continue to be invited, to share their views on green buildings through a survey and other digital platforms.

The SGBMP Working Committee will continue to fine-tune the initiatives and proposed policy levers towards the SGBMP launch, to push boundaries in building performance to mitigate climate change.

## GREEN MARK CERTIFICATION

The Green Mark certification scheme was launched in January 2005. It is a green building rating system designed to evaluate a building’s environmental impact and performance. It provides a comprehensive framework for assessing the overall environmental performance of new and existing buildings to promote sustainable design, and best practices in construction and operation of buildings.

The assessment framework comprises a comprehensive scoring system and verification process to determine how environment-friendly a building or project is.

Green Mark Platinum
Green Mark Gold <sup>PLUS</sup>
Green Mark Gold
Green Mark Certified

*BCA Green Mark Award Rating. Note: Green Mark Certified rating is available only for some of the Green Mark schemes such as Existing Non-Residential Buildings, Existing Residential Buildings, Existing Data Centres, User Centric schemes and Beyond Buildings schemes.*

The total number of points obtained will provide an indication of the environment-friendliness of the building design and operation. Depending on the overall assessment and point scoring, the building will be certified to have met the respective Green Mark rating.

## GREEN MARK FOR SUPER LOW ENERGY BUILDING

BCA introduced the BCA Green Mark for Super Low Energy Building (GM SLEB) during International Green Building Conference 2018 (IGBC 2018) on 5 September 2018. This voluntary certification framework targets new and existing non-residential buildings such as offices, commercial/retail, industrial, institutions and schools, including demonstration projects from Research & Innovation efforts. The scheme aims to encourage industry to push boundaries on energy efficiency to achieve best-in-class building energy performance in a cost-effective manner.

Under the BCA Green Mark for SLEB, there are three building categories - (a) Super Low Energy buildings, (b) Zero Energy buildings and (c) Positive Energy buildings.

Categories	Description
Super Low Energy Building (SLEB)	Best-in-class energy performing building that achieves at least 40%* energy savings based on prevailing code *(equivalent to 60% energy savings above the 2005 building code)
Zero Energy Building (ZEB)	Best-in-class energy performing building with all energy consumption, including plug load, supplied from renewable sources
Positive Energy Building (PEB)	Best-in-class energy performing building with 115% of energy consumption, including plug load, supplied from renewable sources

*GM SLE Building categories*

A Green Mark Gold rating is the minimum requirement for SLE and ZE buildings, in order to meet the holistic environmental sustainability indicators, such as greenery, indoor environmental quality and other non-energy aspects. This ensures the overall environmental sustainability performance indicators are being looked at holistically, while pushing the boundaries in terms of building energy performance.

## Green Mark SLEB Award recipients

A total of 22 projects will receive the GM SLEB Award this year. A range of technologies has been employed in these projects to achieve best-in-class efficiency.



Among the new award-winning buildings is the aircraft hangar for the Republic of Singapore Air Force's A330 Multi-Role Tanker Transport (MRTT) at Changi Air Base designed by the Defence Science and Technology Agency (DSTA).

The hangar will use solar panels as a source of renewable energy and will be able to generate 1,225 MWh of electricity a year.

In addition to the naturally ventilated hangar space, LED lighting and an energy-efficient air-conditioning system are employed to conserve electricity.

The hangar also recycles rainwater for water conservation and has used sustainable building materials such as certified green materials and eco-friendly products. The project is the Singapore Armed Forces' first net positive energy building.

Existing buildings have also hopped onto the bandwagon. One Raffles Link, a super low energy commercial building has undertaken several retrofitting works to attain an

overall cooling system efficiency of 0.6 kW/RT - equivalent to savings of SGD 120,000 per annum.

Examples of such works include utilising a high efficiency chiller system, Air Handling Units (AHU) retrofit with high efficiency fans and replacing of existing lifts with an energy re-generating model.

Additionally, End of Trip (EOT) facilities (such as bicycle parking with shower facilities) for green transport users were also introduced to reduce the carbon footprint.

JTC Space @ Tuas Biomedical Park is located at the heart of Singapore's biomedical park. The specialised development for the biomedical sector employs passive design strategies that include natural ventilation, use of daylight and lush landscape and greenery to ensure occupants' comfort by maximising airflow and mitigating heat absorption.

In addition, JTC installed energy efficiency LED lightings at the common areas such as lift lobbies and carpark to minimise energy usage.

Building Name	Developer/ Building Owner	Award
Changi Naval Base Addition	DSTA	Green Mark Gold (Positive Energy Building)
Choa Chu Kang Columbarium	NEA	Green Mark Platinum (Positive Energy Building)
Hangar Complex	DSTA	Green Mark Platinum (Positive Energy Building)
Administration Building	NTU	Green Mark Platinum (Zero Energy Building)
Block N1.1	NTU	Green Mark Platinum (Zero Energy Building)
Nanyang House	NTU	Green Mark Platinum (Zero Energy Building)
A&A to Existing Block LT5	NUS	Green Mark Platinum (Super Low Energy Building)
Block N3 (MAE)	NTU	Green Mark Platinum (Super Low Energy Building)
Block N2	NTU	Green Mark Platinum (Super Low Energy Building)
COM3	NUS	Green Mark Platinum (Super Low Energy Building)
Central Library	NUS	Green Mark Platinum (Super Low Energy Building)
Knowledge Hub	NUS	Green Mark Platinum (Super Low Energy Building)
NUS Institute of System Science	NUS	Green Mark Platinum (Super Low Energy Building)
One Raffles Link	HKL Pte Ltd	Green Mark Platinum (Super Low Energy Building)
Reconstruction of Existing Single Storey Petrol Station	Chevron Singapore Pte Ltd	Green Mark Platinum (Super Low Energy Building)
SMU A-South 3	SMU	Green Mark Platinum (Super Low Energy Building)
Tiong Bahru Market	NEA	Green Mark Platinum (Super Low Energy Building)
Tuas Biomedical Park	JTC Corporation	Green Mark GoldPlus (Super Low Energy Building)
Ulu Pandan Bus Depot	LTA	Green Mark Platinum (Super Low Energy Building)
United World College of South East Asia	UWCSEA	Green Mark Platinum (Super Low Energy Building)
United World College of South East Asia- East	UWCSEA	Green Mark Platinum (Super Low Energy Building)
LogisTech	CapitaLand Group	Green Mark Platinum (Super Low Energy Building)

Green Mark Super Low Energy Building (GM SLEB) Award Recipients for FY19.

# RAILWAY SYSTEMS

## 'CYBERSECURED BY DESIGN'

by Lee Siu-Min, Director, Security, Thales in Singapore

This can be delivered in compliance with international references and standards.



Ms Lee Siu-Min

### INTRODUCTION

Singapore has outlined its ambitions for a fast, convenient and well-connected land transport network in its Land Transport Master Plan (LTMP) 2040. This vision opens the doors for the rail industry to adopt disruptive technology enablers such as artificial intelligence (AI), big data analytics, the industrial internet of things (IIoT) and cloud computing, to drive digital transformation in rail.

However, critical infrastructure like railway systems, when awash with large swathes of data, can be prone to cyber-attacks that can inflict detrimental impact in many areas, including operational disruption, loss of revenue and reputational damage. The digital railway presents a special challenge to traditional security measures, due to the deployed nature of the assets, and we have seen hackers using COVID-19 disruption to infiltrate corporate networks - a task made easier with millions working remotely on poorly secured devices and networks.

Thales accompanies rail and infrastructure operators in their journey to enhance their cyber-resilience. In Singapore, Thales recently conducted a joint workshop with local key stakeholders in the Singapore rail sector - Land Transport Authority (LTA), and the operators SMRT and SBST - to share and exchange ideas on addressing cybersecurity challenges, which include the supervision of cybersecurity incidents and the corresponding response in both legacy and new systems, and how we can better detect anomalies.

Holistic cybersecurity can be achieved only by addressing the three cybersecurity pillars - Processes, People and Technology - and railway systems are no exception.

### GENERAL PRINCIPLES OF CYBERSECURITY

While security is contextual, security designs are generally driven by the following five universal principles:

#### OPEN DESIGN

The security of any mechanism must not rely solely on the secrecy of its design or its implementation. Proven approaches, mechanisms, technologies, software and solutions provide greater assurance as they have generally been subjected to rigorous scrutiny (including certification) by other implementers in the marketplace.

#### COMPARTMENTALISATION

Compartmentalisation is a security approach whereby a system is segmented into several domains to be protected independently. Each domain consists of one or several subsystems with the same level of trust. Advantages include:

- A security breach inside one entity does not affect other parts of the global system.
- Interactions between components are limited to those actions that are strictly necessary.

This principle applies at the software level (e.g. using signed containers) as well as at the network level, with

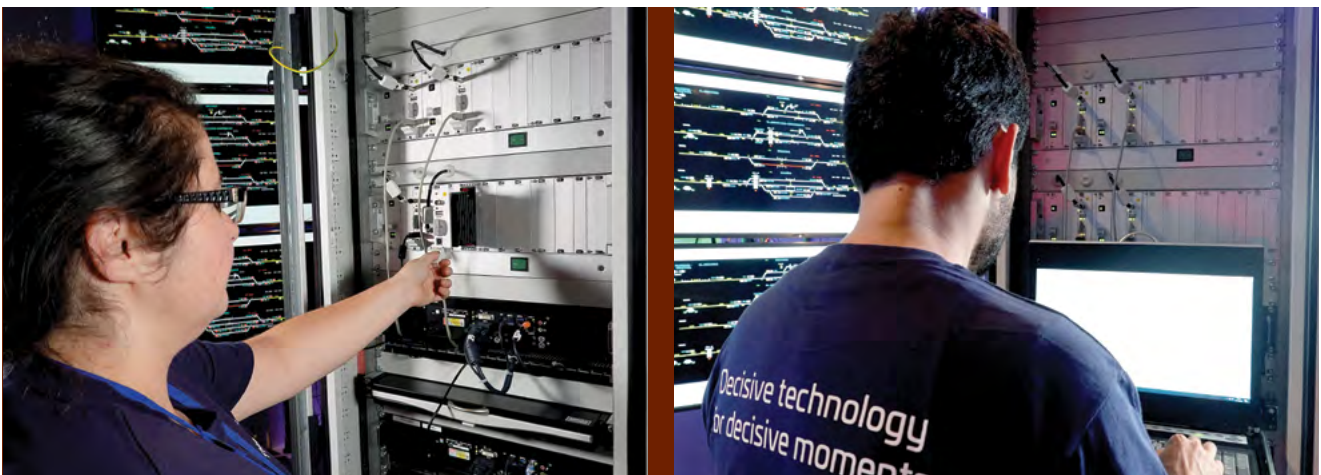

Thales engineers working on the next-generation interlocking product in France.

the segregation of management networks and isolating them from the operational network.

### PERIMETER DEFENCE AND MINIMISATION OF ATTACK SURFACE

Efficient security designs aim at limiting the surface area available for attack and protecting the exposed areas. A typical example is a network perimeter defence which can be implemented via firewalls, proxies and Dual Demilitarised Zones (DMZs), to secure the network interface for a given system that communicates with external systems. In such cases, only predefined messages are authorised. All web access such as e-mail, browsing and file access (which have the potential to import cybersecurity threats inside the perimeter) are not authorised. Moreover, unused services (e.g. SAMBA) and protocols (IPv6) should also be removed.

### DEFENCE IN DEPTH

The principle of 'defence in depth' is about having more than one layer or type of defence. The rationale is that any one layer or type of defence may be breached, no matter how strong and reliable it is, but two or more layers are much more difficult to get through. As an illustration, the security architecture of an IT system can be explained as the superimposing of layers of security measures over one another. When possible, security should not rely solely on point solutions as a single control, as failure may result in a complete breach.

### LEAST PRIVILEGE

This principle requires that a subject (human and software) has the proper and minimum privilege (in terms of scope of resources), and the duration of time necessary for resources to be accessed on the system to perform a specific task. A classic example is to have application services not requiring root privileges to operate. This principle also applies to applications where end-users should receive access only to the functions required for their role. Particular attention should be given to the privileges assigned to accounts needed for operation, administration, and security management.

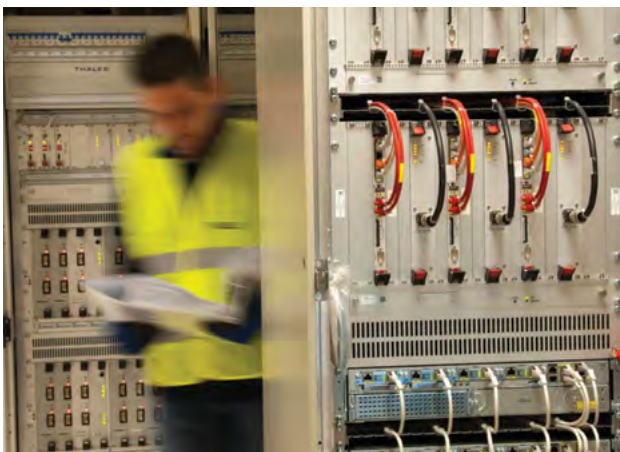

An engineer behind the scenes at a wiring closet at Atocha Railway Station in Madrid, Spain.

## A LAYERED CYBERSECURITY ARCHITECTURE

In order to secure transportation systems, a cybersecurity architecture consisting of complementary security controls must be designed and deployed. Generally speaking, security controls belong to the following layers:

**PHYSICAL CONTROLS** - These controls prevent an attacker from gaining physical access to the system (e.g. network, server, etc), that can be leveraged to perpetuate a cyber-attack. Examples include locks, cabinets, physical access control, etc.

**NETWORK CONTROLS** - These controls secure sensitive data during transmission over wired or wireless networks, maintain the integrity of vital communication, or protect the system from attackers attempting to instigate an intrusion via the network. Examples include external (perimeter) filtering, internal filtering, wireless security, etc.

**HOST CONTROLS:** These controls ensure the security of host machines such as servers, workstations, maintenance laptops and other IT machines. Examples include hardening (both BIOS and OS), host filtering, application whitelisting, malware defence, etc.

**APPLICATION & DATA CONTROLS:** These controls ensure security of the application and data level of the system. Examples include database encryption and file encryption.

## FUNDAMENTAL SECURITY BUILDING BLOCKS

The following fundamental security building blocks should ideally be included in the early design of the railway system.

### NETWORK PERIMETER SECURITY

These days, railway systems are rarely a closed network, instead, they connect to other systems to exchange information related to status, operation, or even revenue. In order to impede any infiltration

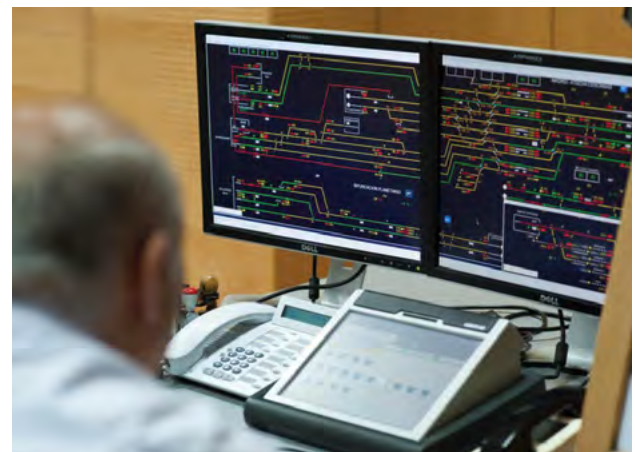

Control centre at a central railway station in Madrid, Spain, with solutions provided by Thales.

attempt from the outside, the following components can be integrated:

- Dual firewall Demilitarised Zones (DMZs) with communication going through proxies and secure gateways.
- Web Application Firewall to protect against web-based attacks.
- Virtual Private Network (VPN) gateways to ensure communication confidentiality, integrity and authenticity, using cryptographic mechanisms.
- Data diodes to implement and guarantee one-way egress communication with external networks.

### INTERNAL NETWORK SECURITY

While the traditional focus was on protecting the perimeter, under the assumption that attackers will come only from the outside, the rise of insider threats has seen 70% of all attacks originating from inside the target system, and attackers who perform lateral movements inside the railway system to compromise other subsystems. Deploying internal network security measures become crucial, via the following:

- Network segmentation with IP/MPLS VPN based on rail subsystems to implement traffic isolation.
- Firewalls that restrict illegitimate traffic from flowing into the networks, for example, deploying Next Generation Firewalls (NGFW) at the entry point of compartmentalised network segments or different sites (e.g. Metro Station, Operation Control Centre, etc).
- Intrusion Detection Systems which can be standalone devices or embedded features within NGFW to implement traffic monitoring and to detect known attacks or anomalies/suspicious behaviour. Potentially, multiple solutions can be leveraged to effectively cover both IT and ICS traffic.

- Network Access Control (NAC) to ensure that only authorised and legitimate devices can connect to the railway network.
- Secure protocols (e.g. TLS) to protect the integrity, authenticity and confidentiality of the communication within the network.

### HARDENING

With the ongoing digital transformation and reliance on IT components, an ever increasing number of 'COTS IT hardware' are present in railway systems, such as workstations, servers, switches and routers. These machines execute 'COTS software' ranging from firmware, OS, and applications.

Hardening procedures aim at reducing the attack surface by ensuring a proper configuration (e.g. setting strong passwords) and removing/disabling unnecessary applications, accounts or permissions, services, or ports.

Special attention must be paid in order not to adversely impact the operation or availability of these systems. For example, removing an 'unused' account, that is reserved for maintenance, will have a negative impact.

### CENTRALISED ENDPOINT PROTECTION

To thwart malware from gaining a foothold in a system, a railway endpoint protection solution with centralised management should be deployed, with the following features:

**Antivirus Protection** - To enable the detection, quarantining and removal of malware, as soon as they are detected in the system. Moreover, appropriate signature update procedures must be established and executed to ensure the latest malware programs are addressed.

**Application Whitelist** - Thanks to the very nature of railway systems and operations, it is relatively easy (contrary to IT environments) to define what applications are allowed to be executed (whitelist). By allowing only whitelist access, malware infection, even when they exploit zero-day vulnerabilities, becomes much easier to control. The application whitelist can be combined with code signing to ensure higher authenticity and integrity.

**Device Control** - This can be configured to mitigate against malware infection via removable media, or even leaking of sensitive information. This allows blocking of external devices such as USB storage ports and, if needed, authorising limited sets of devices to connect exclusively.

### CENTRALISED USER MANAGEMENT

Centralised user management and profiles can unify and simplify a railway system, making access controls easier to manage and maintain across the enterprise. With a centralised authentication system, users are able to access all their work programs and assets through a single set of login credentials.



Using a smartphone with Thales' multimodal contactless ticketing solution in Auckland, New Zealand.

Privileged accounts provide elevated, often unrestricted access to underlying railway systems. These accounts can cause significant operational damage from vectors such as disruption to service, espionage, sabotage, and ransom demands. This renders the system a prime target for both external and internal malicious actors. Centralised User Management enables controlled and secure management of these privileged accounts.

### CENTRALISED LOG MANAGEMENT

Logs, including security software logs, operating system logs and application logs, can contain a wide variety of information on the events occurring within a railway system and network. Coupled with the latest advances in artificial intelligence and big data, logs can provide invaluable insights for different situations, such as detecting cyber-attacks and fraud attempts, predictive maintenance or even training.

A consolidated and centralised platform securely stores all logs for an appropriate duration. This enables regular log reviews and analysis, in order to identify security incidents, fraudulent activity and operational misnomers, as soon as possible, after they have occurred. Moreover, having a centralised log management is also useful for performing auditing and forensic analysis, and establishing/customising cybersecurity-tailored baselines.

With the plethora of information contained in logs, Security Information Event Management (SIEM) systems became a cornerstone to build effective cybersecurity detection and response capability. SIEM's role is to manage, aggregate, qualify and correlate various types of logs, to detect cyber-attacks and respond appropriately.

Having in place a centralised log management system paves the way for smoother and faster integration with an existing or new SIEM. Such an SIEM can be provided as a standalone or as part of an (external) managed service. Without early integration of the centralised log management system into the railway system, designing and integrating a SIEM solution for a railway system can be extremely complex, with potential service disruption or creation of fundamental system flaws that cannot be addressed at later stages.

### CENTRALISED UPDATE SERVER

Railway systems should be designed with 'cyber maintenance in mind'. The Central Update Server (e.g. WSUS) should be part of the railway system, to ensure proper management and distribution of security updates. This enables the operator to rapidly respond to new threats/vulnerabilities.

### CENTRALISED AND SECURE BACKUP

Backup and restoration mechanisms should be put in place, to securely backup systems and configuration settings. This allows rapid recovery and reconstitution of systems in the event of an incident.

### IEC 62443 SUPPORTED CYBERSECURITY ENGINEERING

Last but not least, for safety-critical systems like railway systems, we adhere to international standards like the IEC 62443 series which provides a set of cyber standards to cover all cybersecurity activities needed during the lifespan of the industrial control system. For example, IEC 62443-3-2 combines risk- and design-based approaches for security requirement specification.

During an initial risk assessment, the system is partitioned into zones and conduits. For example, operating assets are separated from business assets and safety-critical assets are separated from non-safety-critical assets. Based on this zone model, in a detailed risk assessment, the target security level is specified for each zone and conduit. This links to a set of technical security requirements contained in IEC 6443-3-3 and 4-2. IEC 62443-4-1 provides the product security development lifecycle to support the design, implementation, commissioning and maintenance of product technical requirements like input validation, via secure coding. IEC 62443-4-1 also requests the traceability of security requirements, provides sound verification and validation testing procedures, and is in line with safety standards such as EN 50128. Additionally, CENELEC TS 50701 on Railway Applications - Cybersecurity gives guidance on security and safety synchronisation points.

### CONCLUSION

Addressing cybersecurity at an early stage of the design is of paramount importance to guarantee the presence, at least, of fundamental security building blocks. This ensures a robust cybersecurity posture with minimum cost. Any delay in addressing cybersecurity will lead to a deteriorated cybersecurity posture, with higher costs when having to address residual risk, let alone the impact of any successful cyber-attack.

Increasingly, railway systems must move to proactive defence such as threat intelligence. Threat intelligence tools can gather information from various sources (national agencies, manufacturers, partners, third parties) and even browse forums (including the dark web), and search for threads mentioning key words or leaked documentation, in order to provide invaluable early warning. This also ensures that railway owners and operators are aware of and up-to-date on their threat landscape and risk posture assessment.

Other examples of proactive defence include the development of tailored cybersecurity systems which are designed and customised specifically for the deployed rail systems, putting in place continuous services such as vulnerability management, in order to maintain the desired level of cybersecurity over time.

All images by Thales

## REAL-TIME DECISION SUPPORT FOR

# TRACTION POWER SUPPLY OPERATIONS

by **Martin Altmann, Dipl.-Ing. (TH) (Regensburg, University Applied Sciences), Siemens Mobility GmbH; Friedemann Koop, Dipl.-Ing. (Dresden University), Siemens Mobility GmbH; and Felix Lerner, Dipl.-Wirtsch.-Ing (FAU Erlangen-Nuremberg), Siemens Mobility GmbH**



Martin Altmann



Friedemann Koop



Felix Lerner

Dependable traction power supply (TPS) availability is a major prerequisite for metro operators to provide high-quality services to their passengers, including under degraded scenarios. Increasing energy prices and social expectations of sustainable electrical solutions that benefit the environment further strengthen the need to consider energy-conscious operations on mass transit networks. Sidytrac RT, Siemens' automated real-time model tool for electrical traction networks provides realistic and verifiable results for traction power supply systems. All relevant energy-related KPIs can be forecasted for desired time-frames. Energy conflicts will be detected before they occur and it will therefore be possible to guarantee a high degree of availability of TPS.

## INTRODUCTION

This article focuses on a new approach for real-time decision support in the field of railway traction power supply (TPS) operation. This automated model, called Sidytrac RT, is developed with real-time processes coupled to operational control systems.

## OPERATION OF ELECTRICAL RAILWAY SYSTEMS

In smart and sustainable city concepts, electric railways, like metro systems, are a key factor. The need for quick trip times and environmental protection, and the reality of increasing energy prices, support the choice of these systems.

For the efficient operation of railway systems, the train operator and the power operator must supervise their respective systems, with the goal of less disruptions and being able to provide sufficient energy to maintain an active overall system when operating.

Urban transport systems are designed for normal operation and can provide a certain amount of spare capacity to allow N-1 degraded operation. Outages of traction power substations (TPSS) impact train operations immensely, e.g. by limiting power availability. Coordination between the train and power operators is essential for increasing the train load, e.g. through reduced headways or longer trains. Also, in the event of an unanticipated

power outage, the two operators should have the ability to cope with the then occurring circumstances.

Ideally, the train operator and the traction power operator should constantly interact. The coordination of both these systems is a key requirement for a high availability transportation system and thus a satisfying journey experience for passengers.

## CHALLENGES FOR TRAIN AND POWER OPERATORS

The challenges for the train and power operators are as follows:

- Coordination between the power and train operators and their supervisors.
- High pressure situations (e.g. outages) requiring on-site personnel to be well-trained and experienced.
- Challenging scenarios and respective impacts cannot be visualised in detail but have to be thought through and solved in a timely manner, to prevent further damage to the system and schedules.
- Forecasting energy and power consumption is challenging, due to a lack of transparency with regard to the indicators and thereby creating the need to rely on rough estimates.
- Because actions of the power operator and the train operator have effects on other systems, a pattern of

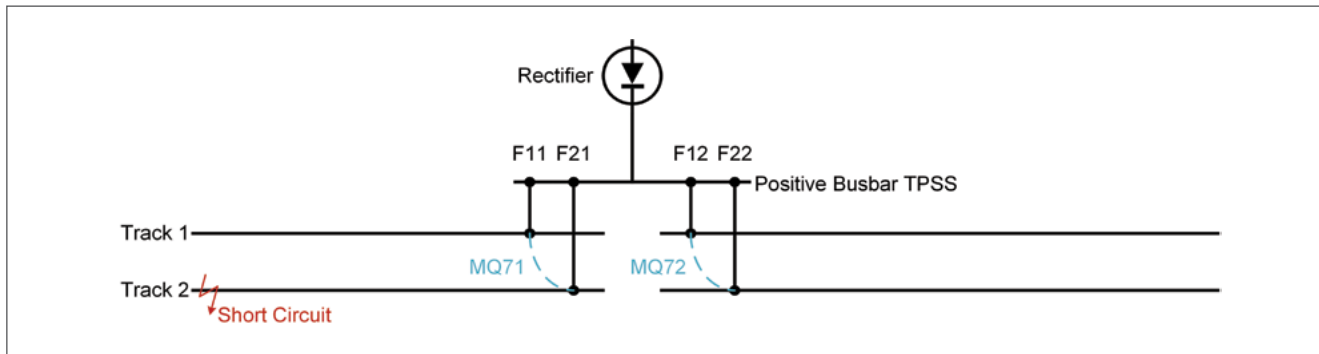

Figure 1: Basic double track TPS with one TPSS including a gap and cross couplings.

the impact of certain actions cannot be explored since several subsystems hinder the transparency.

- The power operator must rely on predetermined switching schemes to cater to potential operational outages. For example, a parallel feeding condition can be established by enabling cross coupling of the contact line, which could sometimes help to avoid the over response of equipment or to stabilise the power supply quality. There is, however, a risk that the protection stability is not guaranteed when cross couplings are enabled.

Figure 1 shows a simplified demonstration of this condition. A simple double track TPS with one TPSS is shown. To separate the feeding sections, a double track gap is built at the TPSS. All four feeding switches in the TPSS are equipped with over current protection devices with a tripping value of 5000 A. Assuming that a short circuit occurs at the end of Track 2, as shown in the figure, causing a current of 6000 A to flow. The protection device for Feeder F21 will trip and the short-circuit will be switched off. To activate cross coupling, MQ 71 is switched on and now the short circuit will be fed by both feeders F11 and F21. In this instance, the total short-circuit current will still be 6000 A but the feeder current is only 3000 A (as F11 and F21 have 3000 A each). The protection device, thus, will not trip and the short circuit will not be switched off. This is undesirable.

For more complex networks, it is often hard to predict the effects on the electrical network when cross couplings are enabled. Power operators have no opportunity to check the protection stability when opting to configure alternative switching scenarios.

## SIDYTRAC RT - REAL-TIME SOLUTION FOR DECISION SUPPORT

### FUNCTIONALITY OF SIDYTRAC RT

Siemens Mobility provides innovative solutions for the needs and challenges faced by both the train and power operators, through the creation of a real-time model of the TPS. This model is called Sidytrac RT and is developed with real-time process coupling to the operational control systems. It is based on real-time SCADA data and

the situation of the actual train operational conditions. This real-time model simulates and forecasts the train operation and electric traction system behaviour for a desired time-frame.

This makes it possible to both simulate energy conflicts, including system breakdowns, before they can occur.

The real-time model utilises the train simulation and load flow kernel of the system design tool and the multi train simulation software Sitras Sidytrac [1]. It covers a wide field of applications such as multi train simulation, load flow and short-circuit calculations for the basic design of electric traction systems, return circuit design and EMI studies, and energy efficiency studies [2]. Therefore, the real-time model offers all the modelling and evaluation possibilities of the professional design simulation software.

The methodology employed offers a wide field of applications, ranging from power control operation and decision support, to general energy management, and can be implemented stepwise with individual modules addressing different needs. In its basic form, Sidytrac RT can be used as an offline application, e.g. as an advanced training simulator integrated with a SCADA training system, or for simulation-based decision support when the power system operator must plan for special operational scenarios. Extending the model further with basic protection functionality enables the user to also perform protection stability checks. Establishing the real-time process coupled to SCADA provides increased depth of information to the control centre.

This is a powerful tool which provides the operator with the ability to assess the reaction of the power system and the supply quality for any intended or planned switching action for train movements, before it is put into operation. It provides the operator with added control over potential disruption scenarios and therefore increases service availability. Sidytrac RT continuously carries out a 'Power System Health Forecast' for the given switching status, evaluating train voltage profiles as well as equipment loading in substations and contact line, as shown in Figure 2. In addition to this, energy consumption and power peak loads in substations can be forecasted.

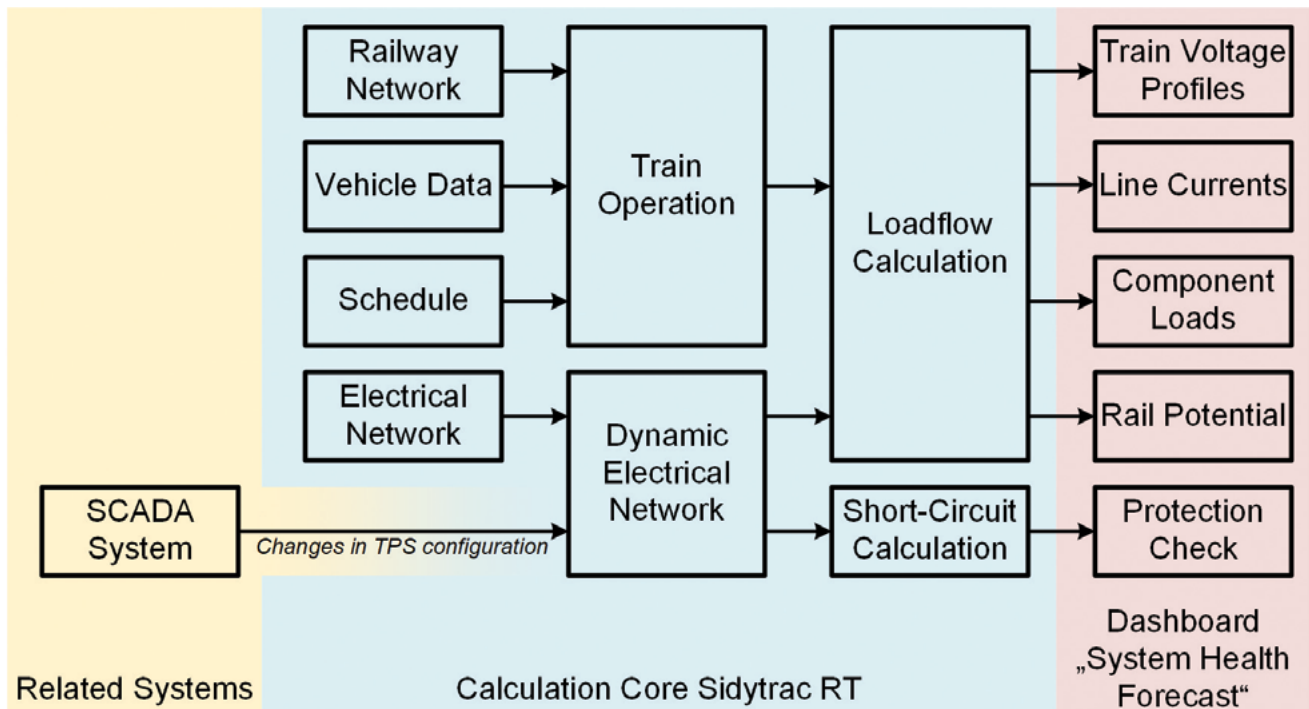

Figure 2: Structure of real-time SCADA connection with Sidytrac RT including different sub-processes and the System Health Forecast shown on a dashboard.

**FEATURES FOR OPERATORS**

**Training system for SCADA applications**

Basically, Sidytrac RT can be used as a digital twin to existing systems, for the training of power operators. In this format, Sidytrac RT is not connected to any related system and works offline. This provides cutting-edge experiences and opportunities to learn, without damaging anything within the system, and gives a deeper insight into the reaction of the system to certain actions.

**Enhancement of power system operations through increased transparency**

Sidytrac RT continuously performs a ‘Power System Health Forecast’ and is therefore constantly forecasting and calculating possible scenarios. Any predicted ‘out of limit’ condition is reported to the operators and hence the operators are supported with higher transparency.

Due to Sidytrac RT providing in-depth information, contact line voltages and rail potentials for each substation are calculated every single step of the forecast period. The transparency offered by Sidytrac RT can be used to make supply and service interruptions easier to assess, as shown in Figure 3. This is especially pertinent to systems which are operated close to their maximum design operational capability (maximum rated power transmission capacity in terms of train frequency and train consist) and which are sensitive to power limitations because of voltage drops. Therefore not only does Sidytrac RT provide higher system availability, also higher system utilisation becomes possible through increased transparency.

In addition, power operators are supposed to meet the daily planned energy and power consumption targets, for economic reasons. Sidytrac RT forecasts both energy and power consumption within the defined period and is therefore a suitable tool to support power operators. This opens the possibility of modifying train operation within a given range, if the forecasted consumption does not fit the planning.

**Planning for modified train operation**

Typically, trainset configurations, new modernised vehicles, reduced headways or combinations of these may modify the original requirements. For the TPS, ever-changing train metrics generate different power requirements and can impact the supply quality negatively. Sidytrac RT can forecast these scenarios and plan for these in advance. Also, operators can then study alternative feeding configurations if the power supply quality is forecasted for the planned reconfiguration. Moreover, when the system is confronted with an unknown scenario, it tries to find and apply the most suitable solution based on previous experience points.

**Protection stability check**

Protection of the contact lines is vital. Relay coordination guarantees the detection of every short-circuit and prevents over response of equipment when operational currents are higher than the protection settings. In relay coordination studies, predefined configurations are developed against the backdrop of worst-case operating scenarios. These worst-case scenarios (outage of substations and feeding conditions with a minimum number of rectification units in parallel) lead to quite low fault levels



with maximum current protection. In actual systems, the number of switching states is way higher than the predefined configurations in relay coordination studies.

Sidytrac RT enables higher flexibility with real-time calculations using the implemented study mode and the ability to check the protection. For the purpose of protecting every switching modification, both the minimum short-circuit current for every feeding section and the highest operational current are calculated. An alarm is generated if one of the considered conditions is not fulfilled, as shown in Figure 4.

## CONCLUSION

Sidytrac RT offers a range of functions which allows decisions to be taken on the feasibility of alternative feeding configurations, without complete information or a sound basis for assessing the full consequences prior to the intended operation. Understanding the impact on the stability of the protection system in advance of interruption scenarios is another area of concern that Sidytrac RT is able to address. These operational aspects are continuous requirements identified by operators who were involved in multiple collaboration workshops during the development of Sidytrac RT.

Future Sidytrac RT developments may also provide new possibilities, by not only checking the stability of the protection system but also adapting protection settings to the actual feeding configuration - which is an opportunity to make the TPS more flexible, capable and available for the operator. As Sidytrac RT is already connected to SCADA, the development of automated adaption of protection settings is close at hand, with Sidytrac RT functionalities.

Finally, getting a deeper insight into the relationship between train operation and traction power supply makes it necessary to adapt Sidytrac RT to other related subsystems. Real-time process coupling of signalling and energy management is a big step forward towards creating a 'digital twin' for metro operation systems. Having a tangible representation of the interdependency between energy consumption and train operation is an

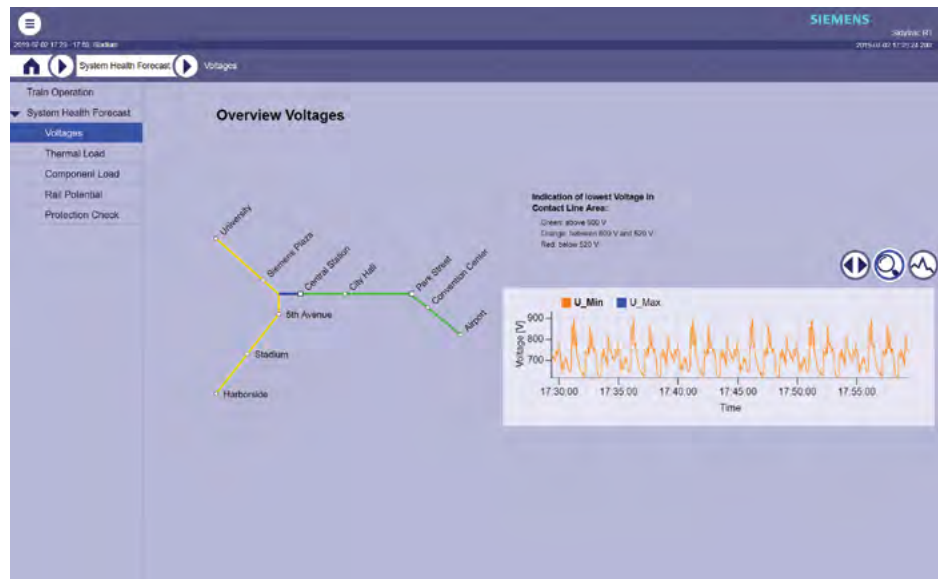

Figure 3: Time series of minimum train voltage for the given forecast period (orange) for a selected line segment in a demonstration network (blue representing the selected line segment, yellow representing line segments with low voltage events, and green representing line segments with sufficient power supply and no impact to train operation).

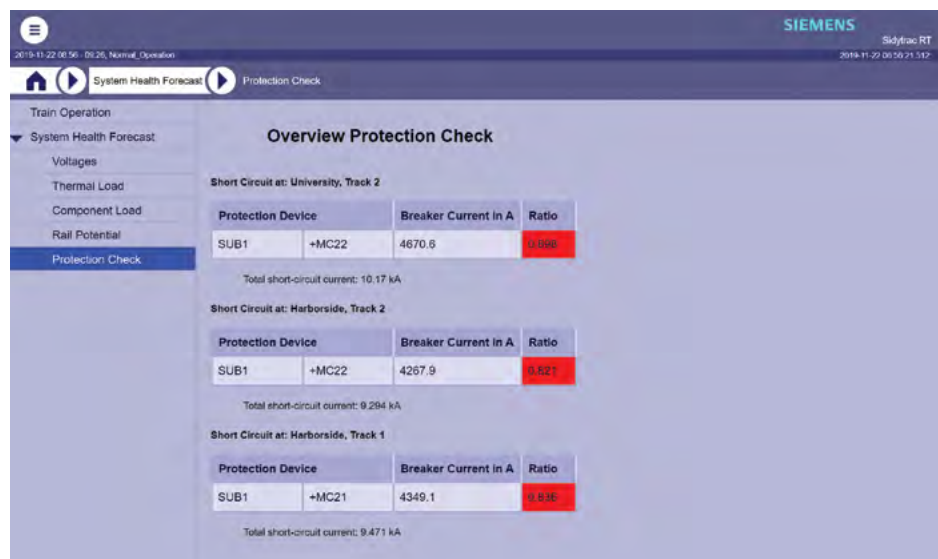

Figure 4: Protection check by calculation of lowest short-circuit currents for entire network and generation of alarms if there are potential undetected fault currents in the respective protection devices.

invaluable tool for operators as they define train movement timetables and train consist types. This transparency also makes it possible to evaluate the optimisation of train headway by considering energy consumption at the same time.

## REFERENCES

- [1] <https://new.siemens.com/global/en/products/mobility/rail-solutions/rail-electrification/planning-and-consulting.html#Simulation>.
- [2] Egid Schneider, Katja Elschner, Andreas Spielmann (2010): How to Increase Energy Efficiency of DC-Traction Power Supplies. 286-292. 10.3850/978-981-08-6396-8\_P076.

## REMOTE COLLABORATION

# SOLVES THE TEST BENCH PARADOX

by Lawrence Liu, General Manager for Asia Pacific, Keysight Technologies

The complexity of test and analysis drives test equipment technology to its limits. The equipment needed is increasingly expensive and offers only enough room to accommodate a few engineers at a time at the bench, while the quantity, variety, and technology levels of devices needing to be tested, are expanding. At the same time, design team size and geographic diversity are growing, and test information needs to flow across organisational and company borders.



Mr Lawrence Liu

The solution to the paradox of test bench limitations versus expanding needs lies in advanced remote collaboration software, which reimagines and improves test bench workflow.

By capturing rich data and saving it to a computer for offline analysis, engineers can manipulate data without physically using the equipment, in order to circumvent bench limitations and constraints. And the ability to share rich data with a worldwide team of experts, means they can continue to independently find insights, do in-depth analysis, and communicate their insights.

### Replacing the old with the new

In a traditional test workflow, engineers plan the test, set up the bench equipment, attach the device under test, and perform the test. Then an engineer analyses static data. But a test engineer working alone at a bench is a relic of a siloed past. Software that leverages a deep level of accessible memory behind each test reading can improve the traditional workflow and the software stores information - beyond what the engineer saw or analysed, for later use.

In the new workflow, an engineer still plans the test, perhaps a bit more carefully, sets up the bench, attaches the device under test, takes the readings, then turns the bench over to the next user. But that is just the beginning.

By using deep, data-enriched snapshots from the bench, after the physical test setup is gone, engineers can do additional signal manipulation and data gathering from those same measurements. They can confer with other subject-matter experts and get input from those experts as to what they might have missed. The whole workflow changes from being 'on bench' intensive, where the highest value and most in-demand assets are, to 'after bench' analysis that is thoughtful, concise, and augmented by expert experience.

For example, when undertaking an electronic emissions pre-compliance test for a Wi-Fi 6 router to see

how this new workflow is effective, an engineer takes one measurement per compliance line item on a test bench in California, USA, then sends that data across the globe for analysis with different protocols and compliance software. Because the router is set for deployment in the US, an electronic emissions test for US standards can use the US standards compliance application.

Those measurements can then go to the EU for analysis against its Wi-Fi 6 compliance requirements. The same set of measurements can later move to Asia for comparison with its requirements. Months later, if the compliance specifications change in any of these locations, an engineer can use those same readings to check against the new standards.

Group input from subject-matter experts is key to achieving the best analysis. Continuing the electronic emissions Wi-Fi 6 router example, what happens if something goes wrong in one of the pre-compliance tests when conducted against standards in Asia, but the problem had not shown up in the US or EU tests? Test engineers across the globe can see one consistent view of the signal of interest, share it, and adopt other views to analyse the problem based on their diverse subject-matter experience.

In a worst-case scenario, if engineers cannot resolve the pre-compliance problem identified in Asia using the prior reading, test engineers back at the bench in California, re-creating the prior setup, can solicit troubleshooting suggestions and take new readings to send to the whole team. A new vocabulary emerges in this reimagined test workflow from a geographically diverse design team gathered in an online meeting - "Capture that and send it to me".

### Major test bench bottlenecks removed

Test engineers get limited time on the test bench. Even if the bench is available and units for test are plentiful,



Measurements being made by an engineer.

the time that a test engineer can spend on any one test or analysis is often short. This limits how many insightful signal views, expert inputs, and software tools, that the engineer can acquire with each reading on a test bench. And test engineers cannot think of all the possibilities during a test because they feel the pressure of others who need that device under test or bench equipment.

Demo or prototype units often have limited availability, especially near the end of the development cycle. When an engineer who tests a design uses a demo unit for less time, yet performs detailed analyses, what-ifs, and other application-driven tests afterwards on a PC, the demo units can be allocated to other stakeholders more efficiently.

Test benches are tight. It would be nice to be able to put 10 experts at the bench who comment and take readings. But there is simply no room. Further, test benches limit the amount of equipment, cabling, and probes that can be used effectively without injecting noise and cross-talk errors into the test.

Taking the opportunity to explore what-ifs and confer with experts is important. If you miss something critical after taking measurements, then you might wish to take just one more view, take one more analysis step, or apply one more built-in software application on that reading. The solution is the new workflow enabled by extended offline capability. Measure once, then analyse afterwards offline.

In summary, the solution to the paradox of bench limitations versus expanding needs requires reimagined test

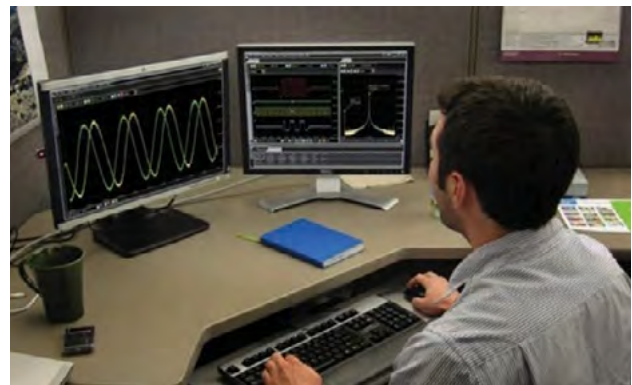

After-bench compliance verification can be done on any PC across the globe.

workflows, powerful collaboration software tools, and an intuitive user interface.

- Reimagined test workflows: The test changes from bench-intensive, where the highest value and most in-demand assets are, to on-bench data-gathering, followed by after-bench analysis.
- Powerful collaboration software tools: Advanced remote collaboration software leverages the bench equipment's powerful processor and deep memory to achieve better results than real-time testing.
- Intuitive user interface: Your personal computer becomes the bench equipment that you already know how to use. It has the same layout and controls, and it offers access to the same applications - so zero training is required.

# HOW DIGITAL TRANSFORMATION IS SHAPING THE OIL & GAS INDUSTRY

by Dr Ravi Gopinath, Chief Product Officer for AVEVA

Adoption of this initiative is vital for optimising asset performance.



Dr Ravi Gopinath

The current pandemic has struck the oil & gas industry, reducing demand due to global lockdowns combined with oversupply, resulting in a 20% imbalance and causing a plunge in oil prices from USD +60/barrel to USD -37/barrel, within weeks.

For safety and efficiency, business continuity is becoming the top focused imperative for most, to sustain operations amidst the chaos. That is why digital transformation is absolutely critical today, more than ever. Keeping critical assets productive is even more challenging, due to the changes in maintenance schedules and in their utilisation, in this heightened period of uncertainty. Only with the right digital tools and software capabilities will successful companies manage the de-manning of production facilities, while keeping their assets productive.

## Implementing Asset Performance Management

AVEVA and Microsoft are helping to drive measurable and immediate results to the workforce, that are improving business performance. Traditional Asset Performance Management (APM) focuses on reliability engineering methods and connects the asset to the person in the different stages of the asset lifecycle, through several layers of enabling technologies. Today, many industries need new data to improve reliability, reduce downtime, and increase productivity.

## Powering with predictive alerts

APM 4.0 applies predictive analytics to the time-series data, to create meaningful, accurate, and specific indicators and alerts, that enable decision-makers



The oil & gas industry has been severely affected by the global pandemic.

to influence the asset's performance before a failure happens. Predictive analytics includes the following three strategies to create alerts:

- **Condition monitoring:** Requiring basic implementation, condition monitoring involves taking one or more sensors, defining a meaningful indicator as an explicit function of the input, and setting a fixed threshold. Should the indicator breach this defined threshold, then it is considered indicative of a problem or failure, and an alert is triggered. The indicator is defined and set in the Historian.
- **Anomaly detection:** This strategy requires Artificial Intelligence (AI), or more specifically, machine learning technology. The algorithm learns a set of time-series training data that reflects the 'normal' operation of the asset. The algorithm runs on a new collection of data to test if it can reliably pick up any anomalies. The significant advantage of this strategy is not having the need to define a mathematical function between the indicator and the sensors, to monitor many different sensors simultaneously.
- **Failure mode prediction:** The ultimate goal in predictive and prescriptive analytics is the accurate and reliable prediction of specific failure modes. It enables precise preparation and a swift follow-



AI can be utilised for predictive analysis.

up to solve the problem. The goal is achieved by monitoring fixed thresholds of sensors. This advanced method is an extension of the machine learning algorithm used to detect anomalies.

### Add-on prescriptive analytics

The right APM 4.0 solution enables decisions to be made promptly, on the prioritisation and scheduling of alerts, so that tasks can be prepared and the availability of spare parts is ensured. By adding prescriptive analytics to the predicted signals, the benefits of APM 4.0 can be maximised and successfully followed up with actions that will improve asset performance. Each triggered alert is linked to prescriptive actions that incorporate four attributes:

- **Criticality:** This is determined by the total financial impact of the predicted failure.
- **Urgency:** This is a reliable prediction of when the failure mode will occur once the indicator alarm is triggered.
- **Action:** This attribute defines the ability to prepare for and respond to a triggered alert. It describes the tasks that need to be executed and includes the required skills, tools, permits, work instructions, and safety of asset-need isolation.
- **Spare parts management:** Having the right spare parts on hand determines whether or not a predicted failure can be avoided.

### The end of unplanned downtime?

APM with predictive and prescriptive analytics enables hydrocarbon producers and refiners to not only remotely monitor asset health but also improve asset reliability, by providing early warning notification and diagnosis of equipment issues - days, weeks, or months before failure. This helps reduce equipment downtime, increase availability, and improve performance, while reducing operational and maintenance expenditures.

## Digital twin alliance to serve the upstream oil & gas sector

DORIS Group, a global engineering and project management company in the energy industry, Schneider Electric, a leader in digital transformation of energy management and automation, and AVEVA, have agreed to develop a strategic partnership to deliver digital twin technology for the upstream oil & gas markets. These new solutions will support the goals of oil & gas organisations to improve asset performance, increase sustainability and maximise return on capital invested in projects.

The three companies will combine offerings to bring engineering capabilities, an asset lifecycle software solution and digital specialisation, in order to create a fully formed digital twin to serve as a backbone for improving the performance of the upstream sector. The new solution is expected to achieve the following:

- Bring new assets on stream faster, through the use of cloud-enabled software that improves collaboration and increases engineering efficiencies.
- Deliver enhanced safety, leading to better business outcomes.
- Improve traceability through single point accountability.
- Enable remote operations and production assurance, through a fully functional, living, digital twin that mirrors all aspects of the operating asset.

### Creating a new offering

Oil & gas owner operators have struggled to go digital due to the lack of a structured offering and orchestration, as no single vendor currently delivers what is required to achieve this. Large amounts of data of various types, from different sources, is another challenge they face, often leading to data inaccuracy and incompatibility, as well as difficulties in organising that data and identifying trends.

Similarly, the oil & gas sector is under considerable pressure to quantify, track and reduce CO<sub>2</sub> emissions as well as reduce overall pollution - this can be even more difficult with limited monitoring, no established method and no data-driven decision-making.

Together, DORIS, Schneider Electric and AVEVA will offer a structured digital and collaborative solution across the lifecycle of projects, that will help oil & gas owner operators address many of these challenges.

# THE SPRAWLING REACH OF COMPLEX THREATS

Trend Micro Incorporated, a global leader in cybersecurity solutions, recently released its 2019 Annual Security Roundup Report. 'The Singapore Engineer' presents, in two parts, edited contents of the report. The first part was presented in the June 2020 Issue of the magazine. Below is the second part.

## Threat actors enhance stealth with crafty components

### Fileless threats become common occurrence

Threats that abuse fileless components differ from traditional malware because, in their case, malicious software or executables are not a prerequisite for infecting a system. Rather, these threats rely on legitimate system administration or penetration testing tools, such as PowerShell, Windows Management Instrumentation (WMI), AutoHotKey, and PsExec, to remain under the radar. Be that as it may, we are able to detect fileless threat-related activities by tracking non-file-based indicators and through technologies like endpoint investigation and response, which can monitor events and analyse what processes or events are triggering malicious activity.

In the past year, we blocked more than 1.4 million fileless events. This large number affirmed our prediction for 2019 that threat actors would increasingly 'live off the land', or take advantage of a machine's built-in applications and tools for their attacks, to evade detection.

This was hardly surprising, especially since numerous malware campaigns were observed using fileless components in their attacks. These campaigns used fileless components in evasion methods, persistence mechanisms, and payload downloading and execution, among other stages of their attack chains.

In March, a campaign targeted three Brazilian banks to access users' banking accounts and steal personally iden-

tifiable information gathered from their visited websites and recorded machine credentials, which can be further abused or sold. The campaign used PowerShell to download a banking trojan.

In August, we uncovered GhostMiner, a fileless cryptocurrency-mining malware variant that weaponised WMI objects for its fileless persistence, payload mechanisms, and antivirus-evasion capabilities. Previously, the variant was observed exploiting multiple flaws in Microsoft SQL Server, phpMyAdmin, and Oracle WebLogic Server to compromise vulnerable servers.

The following month, Emotet re-emerged after a brief hiatus and targeted English-, German-, Italian-, and Polish-speaking users with a spate of spam emails. These emails came with Microsoft Word document attachments embedded with a macro that, if enabled, runs a PowerShell script that downloads the Emotet malware from compromised websites. In the same month, we reported on the Purple Fox downloader malware which we observed abusing PowerShell - its first recorded use of the framework - for its fileless infection capabilities.

Another notable campaign that integrated fileless components into its attacks was KovCoreG. In October, we observed the campaign running a PowerShell script to disable Windows Defender and Windows Update processes. PowerShell was also used by KovCoreG to filelessly execute Novter, which performed anti-debugging and anti-analysis checks, among other backdoor commands.

### Targeted attacks intensify use of complex routines

In targeted attacks, threat actor groups actively pursue and compromise their target entities' infrastructures while remaining unnoticed. Threat actor groups accomplish this by employing tactics, techniques, and procedures (TTPs) that allow them to ensure their attacks continue beyond initial network penetration.

In 2019, we observed a pair of notable threat actor groups that used complex TTPs for cyberespionage: Tick and APT33. For its 'Operation Endtrade', Tick deployed attacks on industries that deal with highly classified information, particularly defence, aerospace, chemical, and satellite industries, with head offices in Japan and subsidiaries in China. Our analysis revealed that the group was still using compromised legitimate email accounts, previously deployed malware, and tools for obfuscation. However, Tick turned out to have improved its arsenal by

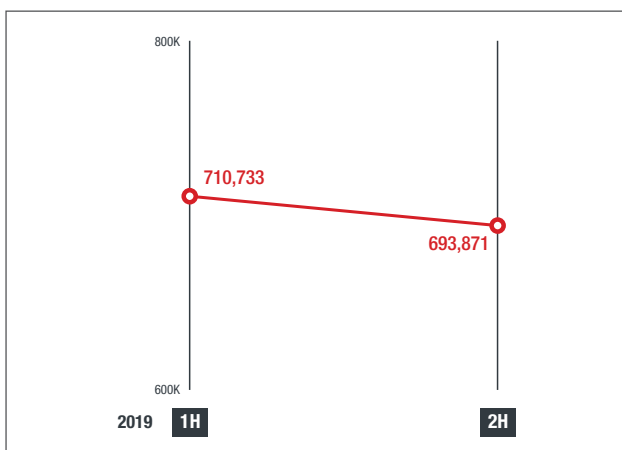

Figure 17: More than 1.4 million fileless events were blocked: Half-year comparison of the number of fileless events blocked in 2019. Source: Trend Micro Smart Protection Network infrastructure.

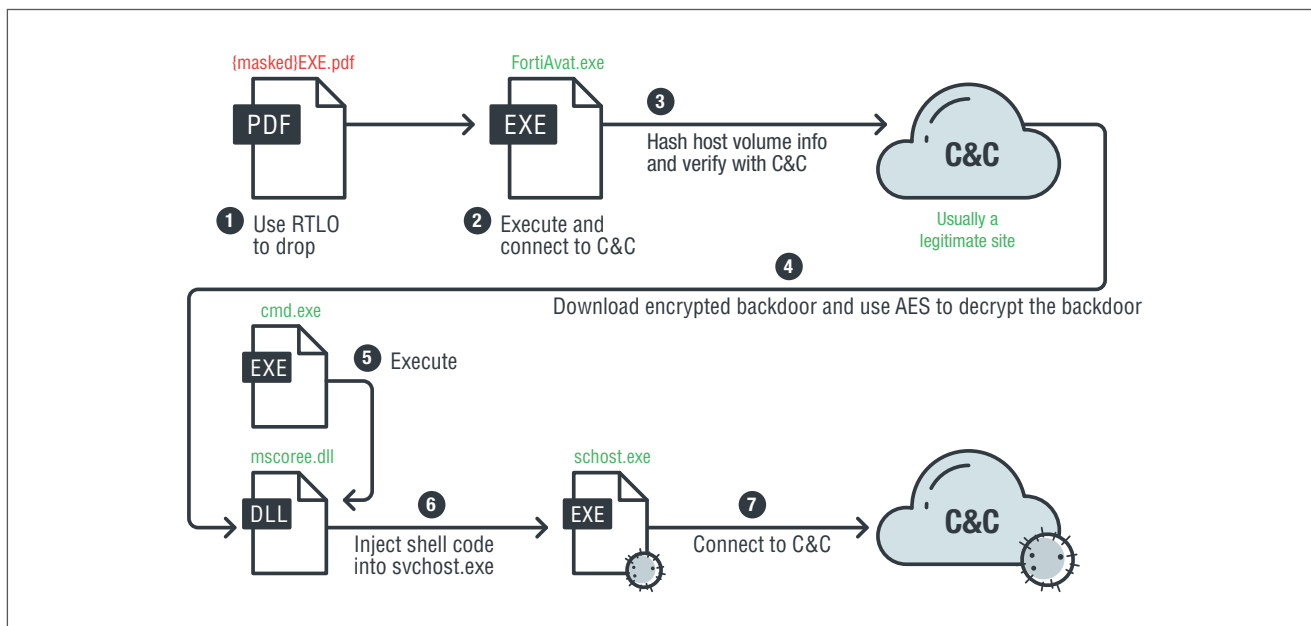

Figure 18: Tick used malware variants that terminated antivirus products: Attack chain of ABK and BBK, downloaders used by Tick. Note: Tick’s complete attack chain, mapped using the MITRE ATT&CK framework, is included in the ‘Threat Landscape in Review’ section of the full report.

including new malware families capable of detection and termination of antivirus products, scanning of operating system code pages to check if they use the language Tick was targeting, escalation of administrative privileges for succeeding attacks, and collection of proprietary information and classified data.

As for APT33, we observed the group using about a dozen live command-and-control (C&C) servers for extremely narrow targeting. APT33 put up multiple obfuscation layers to run these C&C servers in hopes of deploying malware campaigns against organisations based in Asia, the Middle East, and the US. Our analysis indicated that APT33 took a great deal of care to cover its trails. The C&C domains were usually hosted on cloud hosted proxies, and these proxies relayed URL requests from infected bots to back-ends at shared web servers that might host thousands of legitimate domains. The back-ends reported data back to an aggregator and a bot control server that was on a dedicated IP address. APT33 connected to these aggregators using a VPN with exit nodes that were changed frequently, and used the VPN connections to issue commands to and collect data from the bots.

**Malicious actors continue branching out into mobile and other platforms**

**Android malware blights official app store**

Mobile devices, specifically those running on the Android operating system, remained dependable targets for threat actors in 2019. While the number of malicious Android apps that we blocked decreased from the first half of the year to the second, the total for 2019 was still sizeable, at nearly 60 million. This further emphasised cybercriminals’ reliance on attacking mobile devices for stealing credentials, deploying malicious advertisements, and cyberespionage, among others.

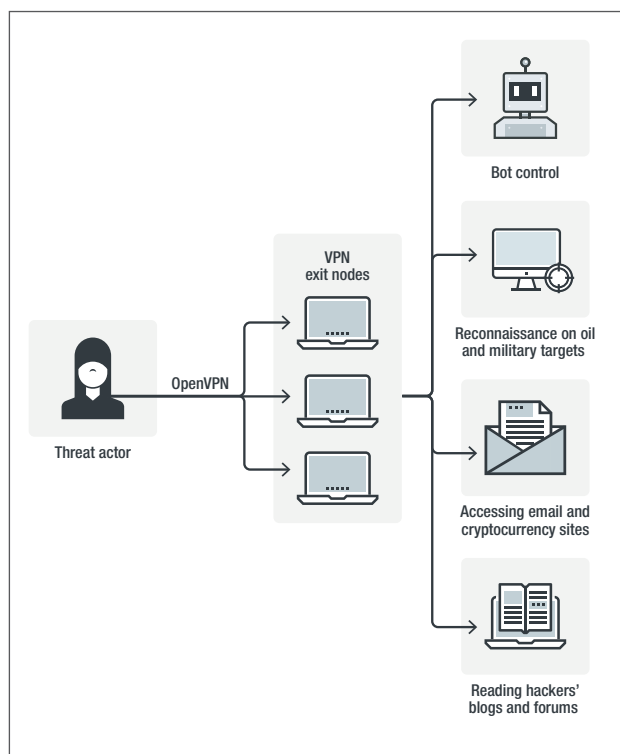

Figure 19: APT33 used a VPN with frequently changed exit nodes: How APT33 used a VPN. Note: APT33’s complete attack chain, mapped using the MITRE ATT&CK framework, is included in the ‘Threat Landscape in Review’ section of the full report.

One of our biggest mobile threat stories in 2019 involved several malicious Android apps that had been downloaded by users a million times. These apps, which posed as beauty camera apps on the official Google Play app store, were found capable of accessing remote ad configuration servers which could then be used for malicious purposes.

In our analysis of malicious samples, we found that it was difficult to see red flags in the apps. One of the samples created a shortcut after being launched, but it managed to hide its icon from the app list. This technique made it all but impossible for users to uninstall the app, especially since they would not be able to find it, let alone delete it.

Another interesting development that we observed in 2019 was the rising number of mobile cyberespionage campaigns, signifying that threat actor groups had also been turning their attention to attacking mobile devices. In the past year, we counted 30 such campaigns, including ones carried out by Poison Carp, Rana, and, most notably, MuddyWater, a notorious cyberespionage group with a history of targeting organisations in Middle Eastern and Asian countries. Our analysis of MuddyWater activities, in particular, led to the discovery of its connections to four Android malware variants that posed as legitimate apps, which were found equipped with information-stealing capabilities.

**Threats break into iOS and macOS**

Apple’s operating systems - iOS for its smartphones and tablets, and macOS for its desktop and laptop computers - have long been considered highly secure, with the company making continuous efforts to introduce new system protections. However, malicious actors have also been relentless in trying to break the security of these devices, churning out threats in 2019 to help them accomplish that goal.

Last year, we found the operators of XLoader, a predominantly Android-targeting malware variant, deploying a scheme that tricked users into installing a malicious iOS configuration profile to steal data from iPhone and iPad devices. We also observed threat actors using an iOS URL scheme that could subject users to privacy violation, bill fraud, and exposure to pop-up ads.

Another of our key iOS threat discoveries involved hundreds of gambling apps that were cloaked in legitimate-sounding names to get past the review process for inclusion in Apple’s App Store. Interestingly, some of the apps ranked in the top 100 list of the App Store, including ones that had been rated more than 100,000 times.

The macOS threats we uncovered involved vulnerabilities and malware variants. CVE-2019-8519, a vulnerability in the graphic drivers installed in macOS Mojave 10.14.3, could allow access to restricted information since it leads to a buffer overflow or segmentation fault. CVE-2019-8635, meanwhile, could enable an attacker to implement privilege escalation and execute malicious code on a macOS device with root privileges.

We also spotted a macOS malware variant that spoofed trading apps to lure victims and steal their personal data. And we discovered a macOS backdoor, attributed to the cybercriminal group Lazarus, that had been deployed against Korean-speaking users through macro-embedded Microsoft Excel spreadsheets. The backdoor was found capable of performing uploading and downloading of files, among other malicious functions.

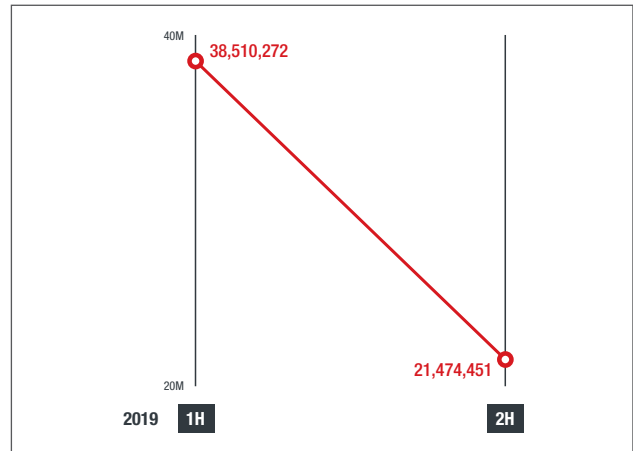

Figure 20: Nearly 60 million malicious Android apps were blocked: Half-year comparison of the number of malicious Android apps blocked in 2019. Source: Trend Micro Mobile App Reputation Service.

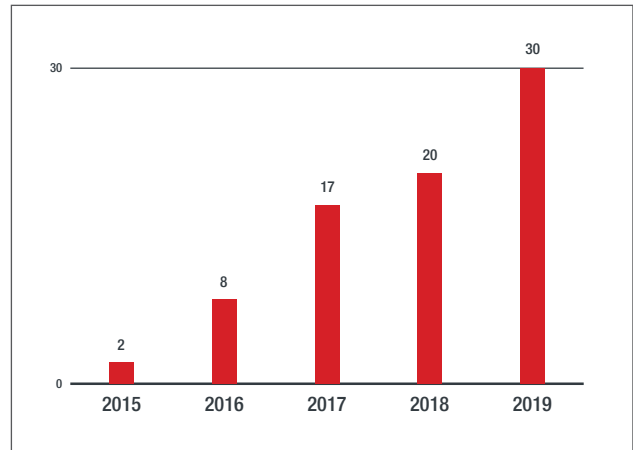

Figure 21: Mobile cyberespionage campaigns continuously increased over the last five years: The number of mobile cyberespionage campaigns from 2015 to 2019. Sources: Trend Micro Mobile App Reputation Service and analysis of externally sourced data.

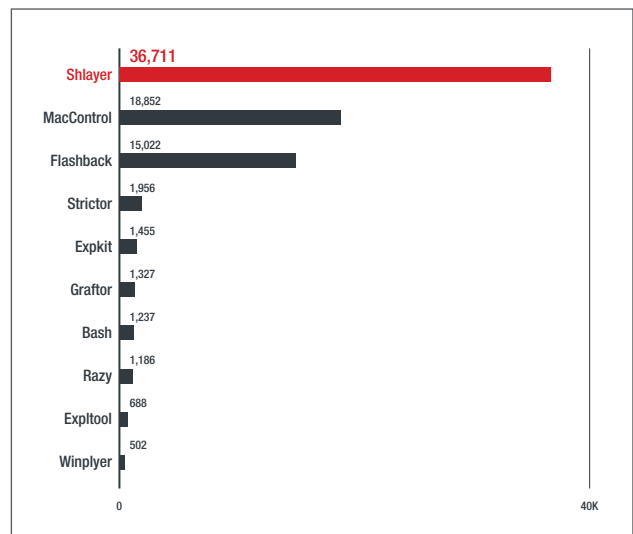

Figure 22: Shlayer was the most detected macOS malware family: Distribution of the top macOS malware families detected in 2019. Source: Trend Micro macOS sample database.



Another notable macOS malware from 2019 was Shlayer, which uses steganography - the practice of hiding code within non-secret text or data - for low-level manipulation of an image file to conceal a script code that downloads adware. Shlayer was also discovered being dropped alongside another macOS malware variant, Tarmac, in a scheme that tricked users into downloading bogus software updates.

Based on our in-house database where macOS samples are processed and analysed, Shlayer was the top macOS malware family in 2019, with more than 36,000 unique detections, nearly 30,000 of which were in the US.

### Multilayered security remains most effective defence against threats

Complex and persistent threats have pervaded the cybersecurity landscape. Collectively, these threats are remarkably industry-, platform-, and device-agnostic, and can effectively take advantage of gaps in new as well as old systems. Enterprises, in particular, must therefore re-examine how they implement cybersecurity and fortify their defences accordingly.

An approach that puts forth a multilayered security strategy is best suited for enterprises dealing with threats that could result in operational disruption, reputational damage, and financial loss. A wide range of security technologies that are functional, innovative, convenient, and cost-efficient can help address the different needs of enterprises. Enterprises should choose solutions that can detect malicious activities in gateways, networks, servers, and endpoints, using a mix of detection technologies such as machine learning, behavioural monitoring, sandboxing, and intrusion prevention. An integrative, attack-centric detection and response solution can also be of great help.

Enterprises should couple their use of multilayered security with industry best practices. Enterprises can stay protected from ransomware attacks by adopting a set of practices that includes creating an effective backup strategy, implementing network segmentation to prevent attackers from accessing parts of the network and corresponding assets in the event of an attack, and monitoring and auditing network traffic for any anomalies or suspicious behaviours.

To reduce the risk of falling victim to messaging threats like phishing and BEC, enterprises should regularly implement security awareness programs. Inculcating members of the organisation

with habits such as checking emails for grammatical errors and spelling mistakes, examining the email sender's display name, and verifying emails that request sensitive information and fund transfers, can go a long way towards thwarting messaging threats.

Enterprises should also monitor vulnerabilities and misconfigurations not only in their own platforms and frameworks but also in those of their third-party providers. Regularly checking systems across the board for flaws and errors can help keep enterprises safeguarded from threats that exploit external partners. Enterprises should also ensure that their systems and applications are updated to the latest versions to forestall threats that rely on critical vulnerabilities. For a more efficient patch management process, enterprises should consider adopting virtual patching which can provide protection against threats that exploit vulnerabilities in outdated operating systems that are no longer being provided with security fixes.

Further, enterprises should keep a regular check on high-privilege software, particularly development tools. To protect these tools from abuse, administrators should always update and strengthen their credentials. Using multi-factor authentication and implementing the principle of least privilege are just a couple of the practices that can shield networks from attacks that rely on compromised tools. Such practices should also be adopted by users for their own computers, smartphones, tablets, and other connected devices.

### Threat Landscape in Review

In 2019, the Trend Micro Smart Protection Network infrastructure blocked more than 52 billion threats, effectively protecting enterprises and users from a multitude of email, file, and URL threat components.

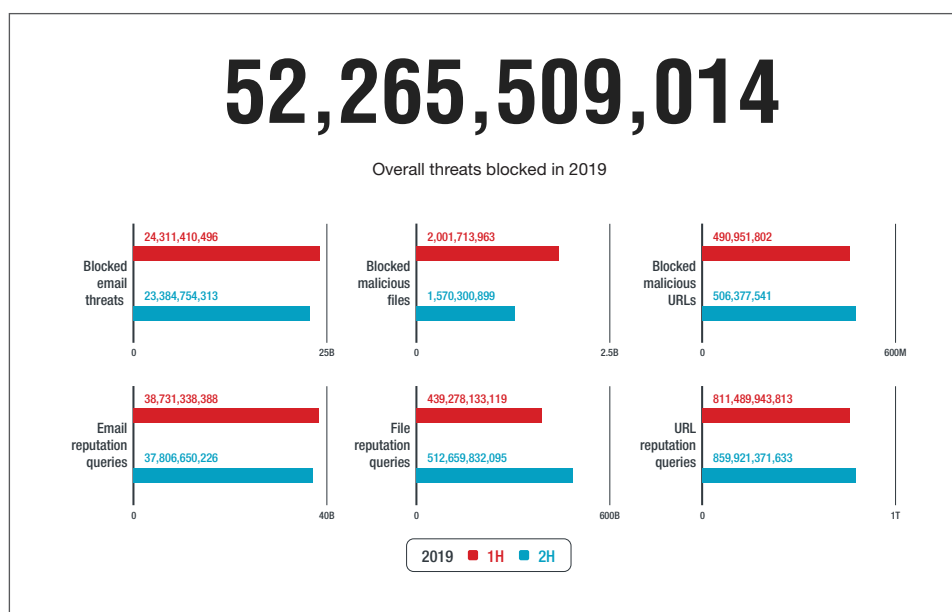

Figure 23: Blocked malicious URLs slightly increased, while blocked email threats and malicious files dropped: Half-year comparison of the numbers of email, file, and URL threats blocked in 2019. Source: Trend Micro Smart Protection Network infrastructure.

Despite their relatively low number, the new ransomware families detected in the past year included several that exhibited fine-tuned capabilities compared with their predecessors or entirely new behaviours.

PDF was the most used file type for spam attachments in our dataset, followed immediately by XLS. Notably, PDF was just behind XLS in 2018.

One of our security predictions for 2019 forecast an increase in digital extortion schemes, particularly sextortion. The substantial number of sextortion-related spam emails we detected in 2019 - more than 14 million - supported this prediction.

We observed a 52% increase in exploit kit activities in 2019, suggesting that exploit kits were still being actively used by threat actors.

GrandSoft was the most detected exploit kit in 2019, with more than 280,000 detections, accounting for nearly half of the total. It overtook Rig which was the most detected exploit kit in the previous year.

Exploit kits still abused old and known vulnerabilities to deliver their payloads, highlighting the need for organisations to regularly patch and update their systems.

The number of disclosed vendor vulnerabilities dropped by 29% from the previous year. Microsoft was the vendor with the most reported vulnerabilities, totalling 190, with Adobe not far behind, with 166. Foxit, Apple, and Google had 70, 60, and 4 vulnerabilities, respectively.

Botnets continued to be active in 2019, with our detections of botnet connections totalling just under 1.7 million, a figure that is virtually the same as the corresponding count from the previous year. The number of botnet C&C servers we detected practically did not change from the previous year as well, at nearly 15,000.

Telnet default password login remained the most triggered event in 2019, yielding close to 600 million counts. The persistence of this event further highlighted the need for changing, updating, and strengthening device credentials.

Attacks that attempted to exploit old vulnerabilities still posed significant risks to users and enterprises.

Our research on Operation Endtrade showed the sophistication of Tick's TTPs against organisations in China and Japan.

APT33, another threat actor group that we observed in 2019, launched attacks on organisations across three continents, that were notable for obfuscating multiple botnets to cover its tracks.

Trend Micro Research remained at the forefront of discovering new threat techniques and developing innovative cybersecurity technologies in 2019. One of our most compelling discoveries came from our analysis of vulnerabilities in radio frequency (RF) remote controllers which are widely used in manufacturing, construction, transportation, and other industrial applications. Our research revealed that RF remote controllers made by

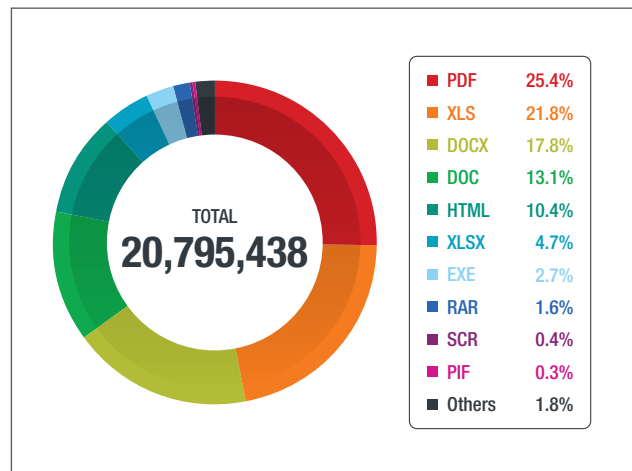

Figure 24: A quarter of the attachments in detected email threats were PDFs: Distribution of file types used as attachments in spam emails detected in 2019. Source: Trend Micro Smart Protection Network infrastructure.

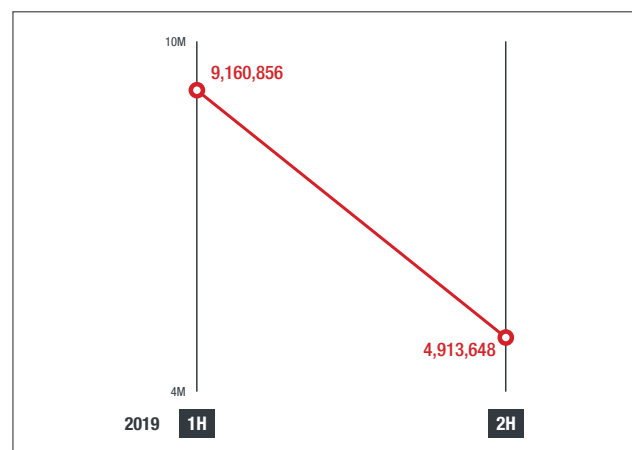

Figure 25: The number of sextortion-related spam emails decreased from the first half of the year to the second, but the total exceeded 14 million: Half-year comparison of the number of detections of sextortion-related spam emails in 2019. Source: Trend Micro Smart Protection Network infrastructure.

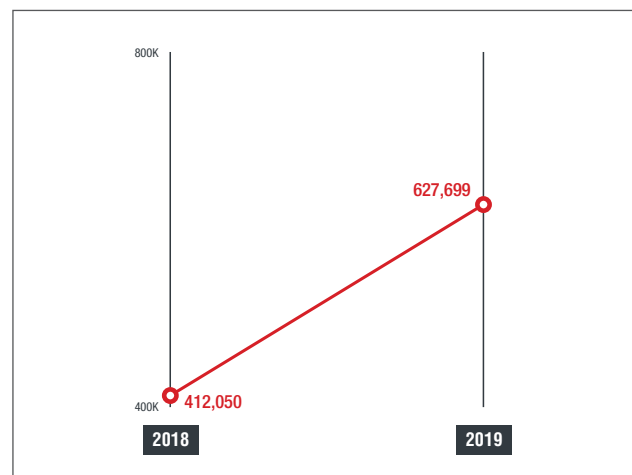

Figure 26: Exploit kit activities increased: Year-on-year comparison of the number of instances of blocked access to URLs hosting exploit kits. Source: Trend Micro Smart Protection Network infrastructure.

several popular vendors lacked security features, and their exploitation could lead to theft, extortion, sabotage, and injury, among other consequences.

We also developed tools that examined data and case studies on Twitter to see how social media could aid in the gathering of actionable threat intelligence. In our study, we proved that the vast amount of information on social media makes it a viable platform for acquiring strategic and operational threat intelligence.

We also emphasised the importance of the application of machine learning in threat detection, with our research on the technology. In two studies conducted with researchers from Federation University Australia, we demonstrated the use of machine learning, specifically the generative adversarial autoencoder model, in the detection and analysis of malware, given a small dataset or even only a single malware sample.

Further, we demonstrated our innovative use of machine learning through the development of a model that uses two training phases to improve detection rates and reduce false positives. Called TrendX Hybrid Model, this model not only identifies malware variants but also predicts their behaviour.

**The research**

The primary source of data is Trend Micro’s Smart Protection Network (SPN), a global repository of threat intelligence. The data is collected from Trend Micro customers who have enabled the feedback mechanism from their products and solutions, allowing Trend Micro to collect threat data and provide better protection. All detected threats are subsequently removed from the customers’ IT environment.

**Disclaimer**

The information provided herein is for general information and educational purposes only. It is not intended and should not be construed to constitute legal advice.

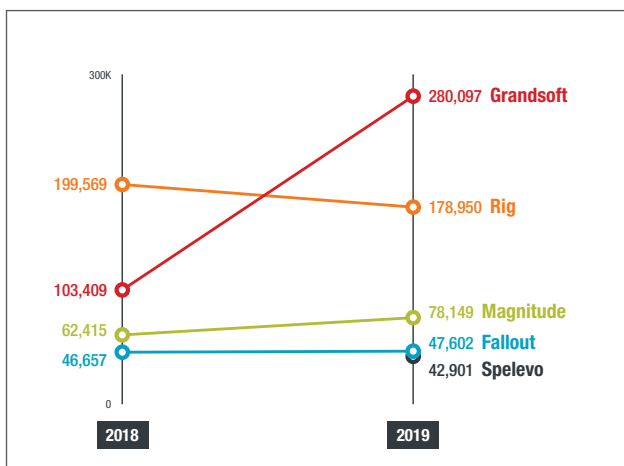

Figure 27: Grandsoft overtook Rig to become the most detected exploit kit: Year-on-year comparison of instances of blocked access to URLs hosting specific exploit kits. Source: Trend Micro Smart Protection Network infrastructure.

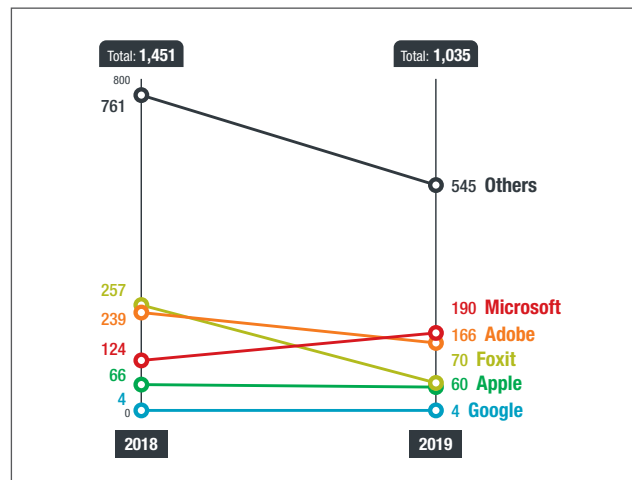

Figure 28: Disclosed vendor vulnerabilities decreased: Year-on-year comparison of the numbers of disclosed vulnerabilities of selected software vendors. Source: Trend Micro Zero Day Initiative program.

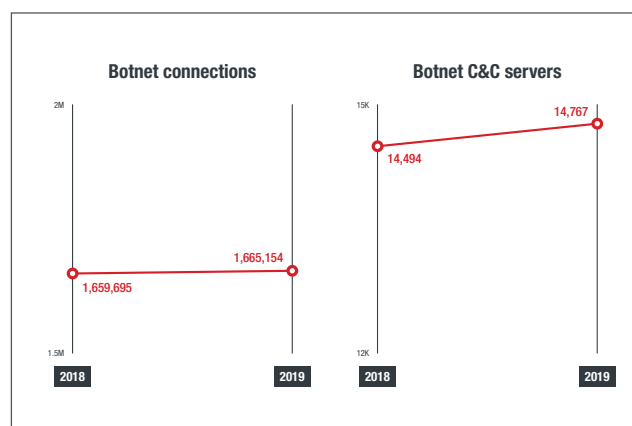

Figure 29: Botnet connections and C&C servers plateaued: Year-on-year comparison of the numbers of detections of botnet connections and botnet C&C servers. Note: Botnet C&C servers were unique and active C&C servers that endpoints queried or connected to, while botnet connections were unique endpoints that queried or connected to C&C servers. Source: Trend Micro Smart Protection Network infrastructure.

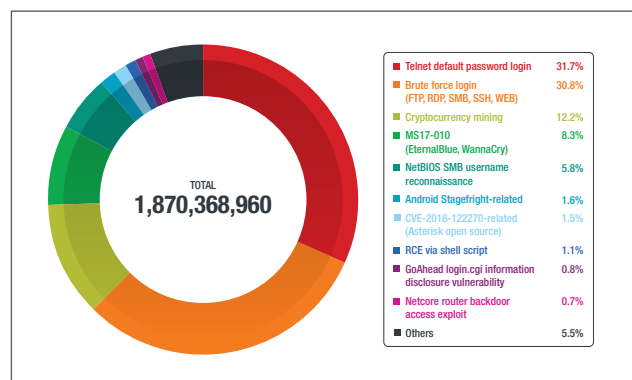

Figure 30: Telnet default password login remained the most triggered event: Distribution of top inbound and outbound events in smart home networks in 2019. Note: Events were when rules were triggered for activities or behaviours from malicious, grey, and potentially unwanted applications, and were indicators that an attack might happen. Possible attacks were events closely related to threat activity. Source: Trend Micro Smart Home Network solution.

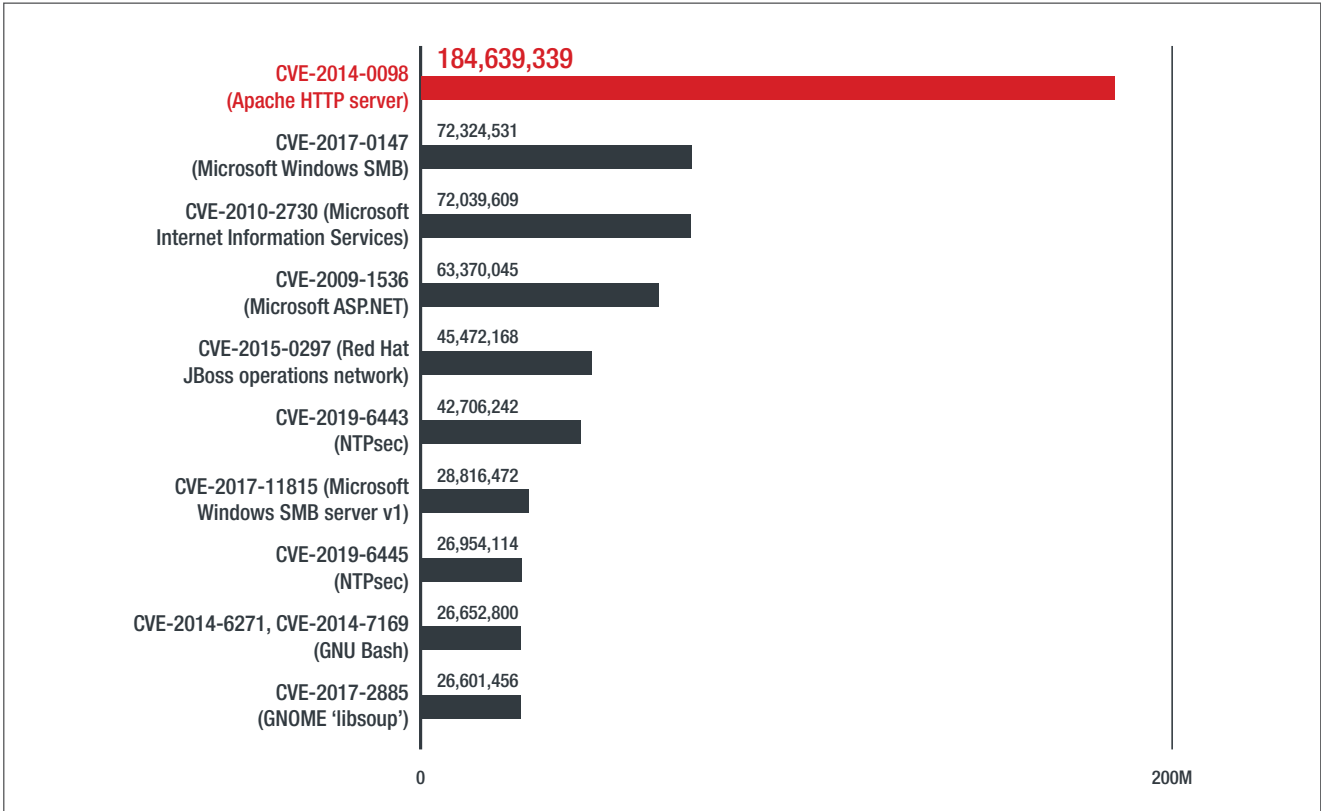

Figure 31: Old vulnerabilities for which patches had long been issued continued to pose security risks to organisations: Distribution of the top filters triggered in 2019 based on feedback from the Trend Micro Deep Security solution. Note: Filters were triggered when intrusion attempts exploiting the corresponding vulnerabilities were blocked. Source: Trend Micro Deep Security solution.

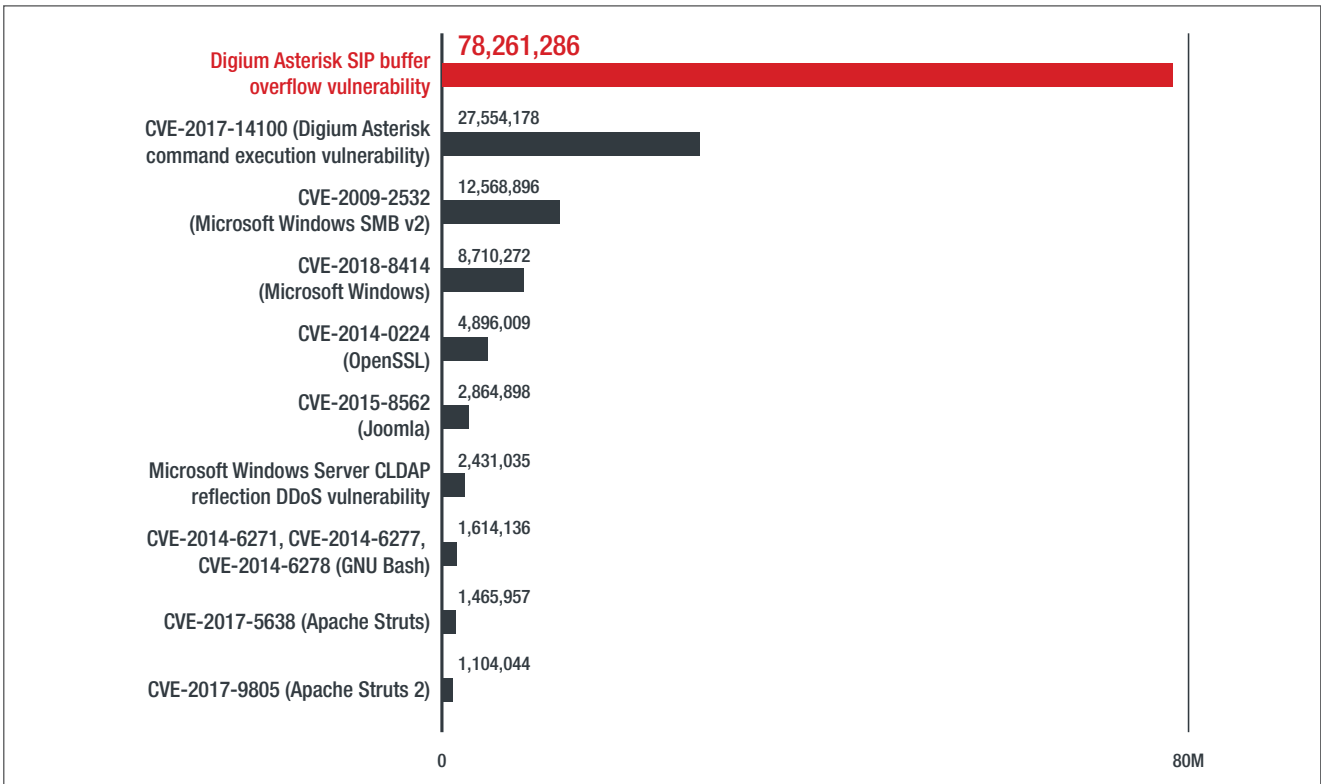

Figure 32: The filter for a buffer overflow vulnerability was the most triggered: Distribution of the top filters triggered in 2019 based on feedback from the Trend Micro TippingPoint Threat Protection System solution. Note: Filters were triggered when intrusion attempts exploiting the corresponding vulnerabilities were blocked. Source: Trend Micro TippingPoint Threat Protection System solution.

# ADVANCED TECHNOLOGY

## TO COMBAT PATHOGENS AND IMPROVE IAQ

Trane, a global leader in climate control technology recently launched a new suite of solutions in Singapore.

These solutions apply advanced technology to reduce contaminants, including particles, gases, bacteria and viruses, in indoor environments. The technology is expected to help people get back to malls and other public areas with added safety and comfort.

As communities re-start activities and businesses reopen, the need is accelerating for building owners to review air-conditioning and ventilation systems to improve air quality in public places.

“As a trusted partner of developers and building operators worldwide, with a long track record of innovation, Trane has recently launched a suite of solutions with significant antivirus capabilities to respond to a variety of public health challenges”, said Mr Allen Ge, President, Asia Pacific of Trane Technologies.

“This is very timely as BCA (Building and Construction Authority), NEA (National Environment Agency) and MOH (Ministry of Health) have recently issued a joint-guidance note on ACMV (Air Conditioning and Mechanical Ventilation) systems in buildings, to improve indoor air quality as part of overall building safety management measures to help safeguard public health”, he added.

Mr Ge explained that Trane is assisting building owners and operators with more precautionary measures to help reduce public health risks, in addition to wearing masks, social distancing, and more frequent cleaning of high-touch points in buildings, during and beyond this pandemic period.

“We are the first in this market, with the Trane Air Cleaning System which combines advanced technologies to offer safe and more effective solutions to safeguard pub-

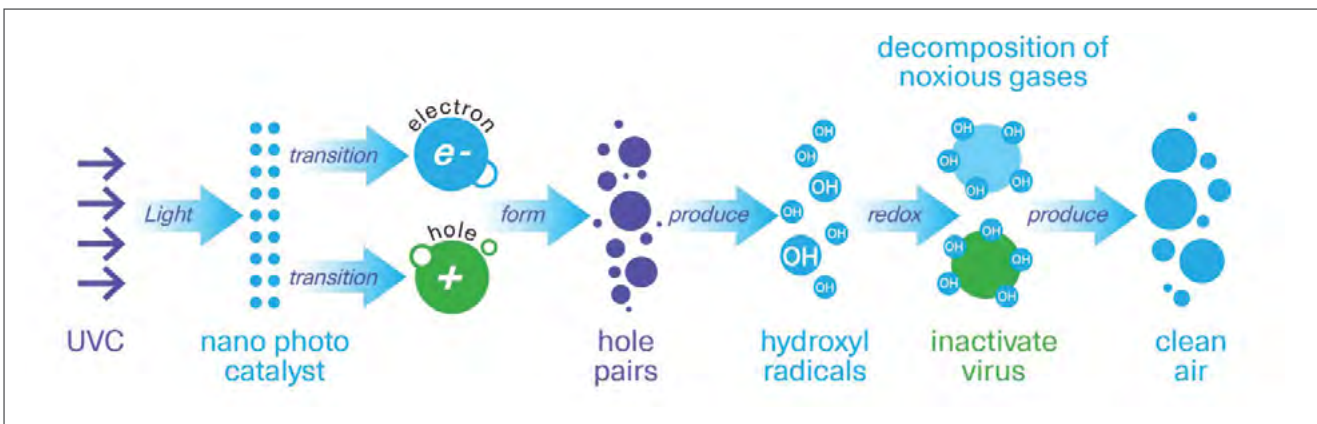

Working principle of the photo-catalytic oxidation (PCO) filter.

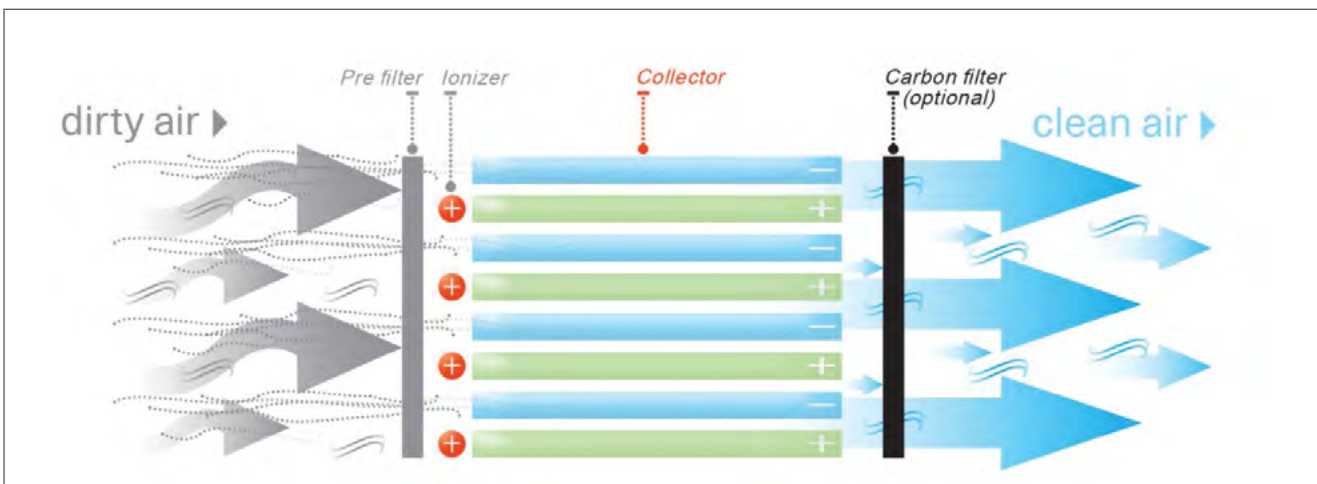

Working principle of the high voltage electrostatic filter.

lic health, rebuild social and economic vibrancy, and also meet the needs for sustainable and comfortable cooling and air management systems”, Mr Ge said.

### Technology to combat pathogens

Trane's latest suite of air cleaning systems uses both photocatalytic oxidation and ultraviolet light (PCO+UVGI), along with electrostatic filter technology.

Photo-catalytic oxidation (PCO), through a process called photo-catalysis, uses ultraviolet radiation to create powerful oxidising agents which oxidise harmful volatile organic compounds (VOCs) and converts them into harmless chemicals such as carbon dioxide and water. These oxidising agents also kill microorganisms (bacteria and viruses) or render them ineffective.

Ultra-violet Germicidal Irradiation (UVGI) has a dual purpose. Its primary function is as an energy source that facilitates the catalytic reactions in the PCO process. It also has a germicidal effect on microorganisms. The ultraviolet light in the 'C' band (UVC) damages the DNA or RNA and inactivates a wide range of microorganisms, including fungi, bacteria and viruses, commonly found in buildings.

These systems not only reduce the risk of transmission of certain pathogens, but also improve air quality by effectively eliminating many gases and offensive odours, and filtering particulate matter (PM2.5) in the air.

Mr William Liu, Technology Development Leader and Principal Engineer for Trane Technologies Engineering & Technology Center in Asia Pacific, explains, “Our unique Trane Air Cleaning System combines filtration and PCO+UVGI to help remove pathogens and particulates from the air in all types of buildings. In areas with high transmission risks such as medical facilities, our solutions can help to reduce the spread of airborne diseases such as influenza”.

The building types include education facilities which have an occupant density up to six times higher than commercial and retail spaces, thereby increasing the risk of airborne diseases.

“With our solutions, we help to create a safer environment for children to learn and grow. According to test reports, our solutions are effective in delivering an improved air environment, achieving an MS2 virus reduction rate of over 97%”, said Mr Liu.

The MS2 virus is a simulant for the human influenza A virus (H1N1).

Trane's solutions also have low air resistance and almost no additional energy consumption impact on air-conditioning systems, making them sustainable options for building owners and operators.

### Helping businesses reopen safely

With the growing focus on indoor air quality (IAQ), especially during the ongoing pandemic, Trane's industry-leading initiatives have been well-received. The company has received more than 2,500 enquires across 11 countries in the Asia Pacific region and close to 190 orders from customers across different industries.

In Singapore, Wisma Atria shopping mall will be the first to use the Trane Air Cleaning System. The award-winning shopping mall, situated along Singapore's upscale shopping area, is installing the system to support its clientele.

Ms Ong Mei-Lynn, General Manager of YTL Starhill Global Property Management Pte Ltd (which manages Wisma Atria), said, “The safety and comfort of our customers, tenants and other building occupants are our top priority. As we reopen for business, we emphasise the importance of indoor wellness and we are taking stringent steps to minimise or eliminate indoor pollutants, in addition to the guidelines provided by the Singapore government agencies. We hope to utilise the air cleaning solution developed by Trane, to provide a safer, healthier and more comfortable environment for our shoppers and tenants at Wisma Atria”.

In addition to providing improved IAQ, the system is versatile. It can be installed in a new building or retro-fitted into Trane and other brands of air handlers, and duct-mounted systems.

### Additional information

There is evidence from The American Society of Heating, Refrigerating, and Air-Conditioning Engineers (ASHRAE) and other sources that Heating, Ventilation, and Air-Conditioning (HVAC) technologies can mitigate the risk of exposure to infectious aerosols in built environments. However, the transmission and mitigation of COVID-19 in buildings are yet to be tested and confirmed.

All images by Trane

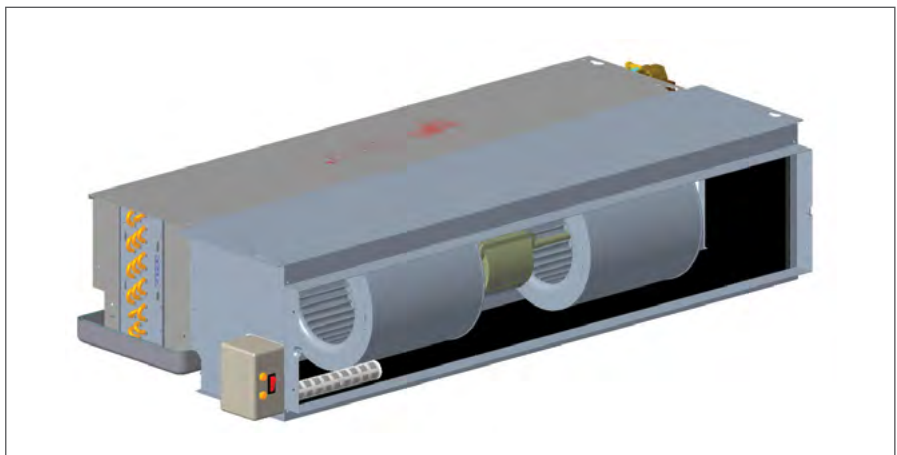

Plug-in PCO filter installed in the return plenum of a fan coil unit (FCU) in an Air Conditioning and Mechanical Ventilation (ACMV) system.

**HIGH INTEREST**

**IN SINGAPORE AND THE REGION**

Mr William Liu, Technology Development Leader (Principal Engineer), Engineering & Technology Center - Asia Pacific, Trane Technologies, elaborates on the demand and application areas for the new suite of solutions.



Mr William Liu

**Question: Which are the main countries that have shown an interest in Trane’s new suite of solutions and what are the main commercial, institutional, industrial and other building types that have sought these solutions?**

Answer: In the Asia Pacific region, Trane has received more than 2,500 enquires across 11 countries and close to 190 orders from customers across different sectors, including healthcare, hotel, education, retail and office.

We have received many enquiries regarding our Trane Air Cleaning System, from China, Singapore, Thailand, Taiwan, Japan and Philippines, where we have won orders of varying project values. Particularly in China and Philippines, we won some major orders.

We launched these solutions less than three months back and we are expecting more wins in the coming months.

Interest is high, as all building operators are preparing their facilities for increased occupancy and traffic. The antivirus solutions provide an additional safeguard on top of all the safety measures in place. Building owners and facility owners also want to create differentiation amongst themselves to increase their customer retention rates and attract more visitors.

**Q: Could you comment on the safety of Trane’s UV-based solutions, for ACMV installation and servicing personnel as well as the occupants of buildings, considering that UV-disinfection could cause damage to the eyes and skin?**

A: The safety aspects of UV-C are well-known. It does not penetrate deeply into human tissue, but it can penetrate the very outer surfaces of the eyes and skin. As a leading, global climate controls company, Trane has well-trained service professionals to ensure high-quality service delivery to our customers by following strict operational procedures to avoid UV radiation damage. For example, we have lockout/tag out procedures to ensure the power cannot be inadvertently energised during the servicing.

Moreover, the products are installed inside AHUs/FCUs which are located in M&E plant rooms and/or above ceilings, where the exposure to occupants is almost zero, and these areas/spaces are accessed only by trained service professionals.

**Q: How well is Trane positioned in Singapore to address the challenges relating to ACMV systems?**

A: Trane believes that continuous innovation is the core driving force to sustain the company’s long-term success. As early as in 2003, we established the Asia Pacific Engineering & Technology Center and we continue to look into investments in new technology and solutions that would provide people with a safe and comfortable indoor environment, while improving the safety of public facilities and delivering value-added services for our regional customers.

People’s safety and health are our topmost priority, and our launch of this air cleaning system is a powerful and innovative weapon in the battle against COVID-19.



The Trane Air Cleaning System installed in an AHU.



Full cross section of the PCO module for the AHU.

# FLEXIBLE AND INTUITIVE CONTROL

## TO OPERATE COMPRESSED AIR STATIONS EFFICIENTLY

With the airtelligence provis 3, BOGE KOMPRESSOREN is said to set new standards for the networked control of compressed air compressors. With the latest version of the intelligent control, an unlimited number of compressors and accessory components can be managed proactively, and based on consumption. Users can also control any number of compressed air networks via the airtelligence provis 3. A fully-integrated, high-performance industrial PC makes the system into a complete solution that is ready for connection. It is operated via an intuitive touch display or remotely, for example, via a terminal. All machine data can be called up at any time, almost in real-time.

The previous version, airtelligence provis 2.0, controlled interaction of up to 16 fixed or frequency-controlled compressors and a limited number of accessory components. With the airtelligence provis 3, the hardware and software are dimensioned in such a way that an unlimited number of compressors and components can be connected and operated. As Ethernet is used as the communication standard, it is possible to revert to existing IT infrastructures, and fast and simultaneous communication can be carried out between several participants. Thanks to the new Modbus interface module, the airtelligence provis 3 also integrates external compressors in a straightforward way.

To facilitate communication between products from different manufacturers and for different devices to work safely and reliably, the BOGE control uses the OPC UA open data format. The airtelligence provis 3 can also control different compressed air networks, and this is a new feature on the market.

The healthcare sector, for example, requires a sterile air network to operate alongside other compressed air networks. And because each network requires separate controls, this can complicate matters. The airtelligence provis 3 offers the optimal solution.

The intuitive touch operation simplifies usage. Detailed compressor view, profile view or pressure gradient can be seen on the optimised 15.6 inch display. Irrespective of whether it is on the integrated display, or on the PC,

tablet or smartphone, the comprehensive visualisation is web-based and can be called up and operated from anywhere, and is equally clearly presented on any terminal or device. It shows status values almost in real-time, as well as consumption flows. A new feature is energy reporting according to the DIN ISO 50001 standard. In accordance with efficient energy management, the user can trace the energy costs for operating the compressors at any time.

The high-performance control algorithms of the airtelligence provis 3 select the optimal combination of compressors and additional components proactively, and based on consumption. This avoids energy-intensive over-compression and optimises operations for load run or idle times.

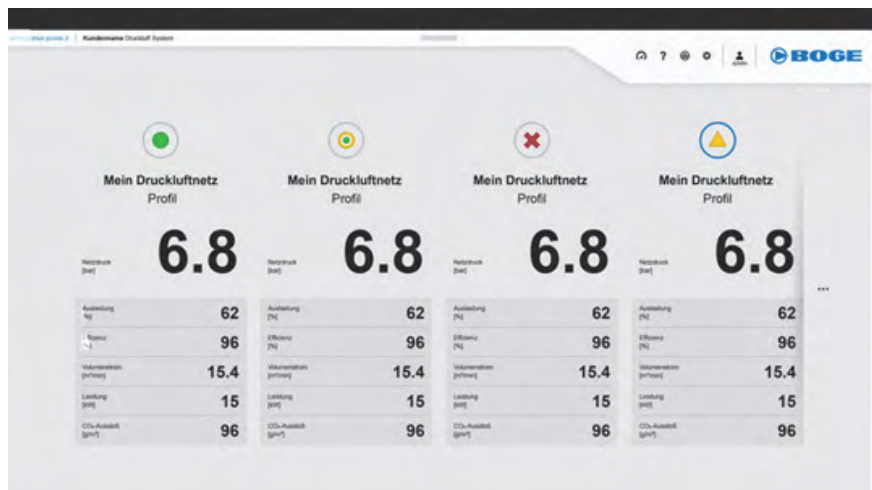

The intelligent control, airtelligence provis 3, from BOGE KOMPRESSOREN, links data from an unlimited number of compressors and components. Image: BOGE KOMPRESSOREN.



The comprehensive visualisation of the airtelligence provis 3 clearly displays status values and consumption processes of the compressors, which can be retrieved from anywhere. Image: BOGE KOMPRESSOREN.



# ICYMI: TECHNICAL COMMITTEE EVENTS ROUND-UP

## BES-IES Joint Seminar on Healthcare Engineering

6 July 2020

On this date, the IES Biomedical Engineering Technical Committee, in collaboration with the Biomedical Engineering Society (Singapore) (BES), conducted an online joint seminar on the topic of healthcare engineering.

The invited speakers were Mr Takahiro Hirayama, a certified clinical engineer from Okayama University Hospital in Japan, and Mr Gary Lim Bing Boon, a senior engineer with Khoo Teck Puat Hospital's Biomedical Engineering Department.

Mr Hirayama elaborated upon the diverse roles of clinical engineers in Japan, while Mr Lim spoke about the current landscape for Singapore clinical engineers in the two-hour seminar.

The online event attracted more than 200 medical and clinical engineering professionals and specialists from Singapore and other countries such as Australia and Myanmar. It was also livestreamed to Chinese biomedical engineering community on the Chinese Journal of Medical Device's online platform.

Image credit: Youtube/BES – Joint Seminar on Healthcare Engineering



## Online Technical Presentation on Power Transmission – From Failure to Re-Design

29 July 2020

The Precision Engineering Technical Committee organised a webinar on 29 July 2020, which was attended by more than 60 participants, mainly PEs and Mechanical & Electrical Engineering Resident Engineers and Resident Technical Officers.

The speaker was Mr Robert Shandro, Principal Consultant at Matcor Technology & Services. He presented a technical paper titled “Power Transmission – From Failure to Re-Design”, which discussed using a failure analysis approach to understand power transmission failures through some case studies.

Mr Shandro is a veteran mechanical engineer with more than 30 years’ experience, specialising in power transmission components.



# IES HOLDS 54<sup>TH</sup> ANNUAL GENERAL MEETING ONLINE

Amidst the COVID-19 pandemic and the need to ensure social distancing, IES held the 54th Annual General Meeting (AGM) online on 26 July 2020.

An unprecedented first for IES, the AGM took place through a Zoom-powered meeting platform provided by event technology solutions firm Globibo, and was attended by more than 230 members.

Prof Yeoh Lean Weng officially handed the reins over to Dr Richard Kwok, who officially began his term as the 28th IES President that day.

“I am humbled and excited to be elected as the 28th President of IES and to serve during this extraordinary time ... I am committed to steer IES, the national society of engineers in Singapore, to support the engineering community in developing innovative solutions to strengthen Singapore’s competitiveness and create a better future for Singaporeans,” said Dr Kwok.

Several matters were discussed at the AGM. Apart from the annual updates on IES matters and financial performance, members also voted on several constitutional amendments, mainly aimed at admitting technologists and technicians from engineering-related fields into IES to promote a more inclusive engineering community.

All material from the AGM will be made available on the Members’ Portal when ready.

The new council (Session 2020/2021) looks forward to serving the engineering community in the upcoming term.



Prof Yeoh handed over leadership of IES to Dr Kwok in a virtual ceremony.



The 54th AGM was held online, a historic first for IES.



The members of IES Council Session 2020/2021.

## ADVERTISERS’ INDEX

- IES Chartered Engineer ————— Page 01
- IES Membership ————— Inside Back Cover
- IES Railway Systems Handbook ————— Page 13

Singapore University ————— Inside Front Cover of Social Sciences

Who’s Who In Engineering, ————— Outside Back Cover Singapore (3rd Edition)

# THE HEART & VOICE OF ENGINEERS



## IES Membership

### 1) Professional Development

- Eligible for Chartered Engineers Certification Application (subject to registration criteria and conditions)
- Enjoy preferential rates for IES conferences, seminars and workshops
- Enjoy 10% to 15% discount for IES Academy Courses (T&Cs apply)

### 2) International Affiliations

- Interaction with overseas engineering institutions in joint programmes

### 3) Networking

- Exclusive FREE Members' Night (T&Cs apply)
- Enjoy preferential rates for networking activities
- Join our Sports Interest Groups
- Join our Social Events



### 4) Communication

- Enjoy free subscription of IES weekly e-Newsletter
- Free monthly e-zine – The Singapore Engineer
- Free Annual IES Directory containing the business contacts of all members
- Get the latest updates on government regulations and the activities of allied institutions

### 5) Others

- Enjoy special rate for IES professional Indemnity Insurance Schemes
- Enjoy exclusive merchant benefits
- Free parking in IES premises
- Get a 5% discount off your membership subscription when you pay by GIRO (T&Cs apply)

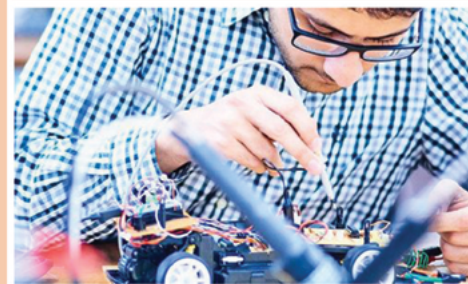

## Join Us!

[www.ies.org.sg](http://www.ies.org.sg)  
64695000

**25% OFF**



## WHO'S WHO IN ENGINEERING, SINGAPORE (THIRD EDITION)

A prestige publication that showcases over 250 Singapore's prominent engineers and their outstanding contributions in the respective industries.

**25% off @**  
**S\$96.30\*** each

*(incl. GST)*

**RSP: S\$128.40**

\* Valid till November 2020

\* While stocks last



**SCAN THE QR CODE  
TO SECURE YOUR COPIES NOW!**